

Service
Service
Service



Service Manual

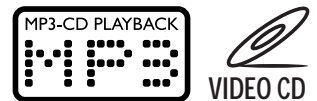

TABLE OF CONTENTS

Handling chip components1-1
 Information about lead-free soldering1-2

Technical specification2-1
 Service tools2-1
 Service measurement setup2-2

Connections and controls3-1...3-2
 Maintenance and troubleshooting3-3

Disassembly diagram4-1...4-2

Set block diagram5-1
 Set wiring diagram5-2

TUNER BOARD
 circuit diagram6-1
 layout diagram6-2 6-3

AUDIO BOARD
 circuit diagram7-1
 layout diagram7-2

CONTROL BOARD
 circuit diagram8-1
 layout diagram8-2

CASSETTE BOARD
 circuit diagram9-1
 layout diagram9-2

VCD BOARD
 circuit diagram10-1
 layout diagram10-2

Exploded view diagram11-1
 Mechanical partslist11-2

Electrical partslist12-1...12-4

© Copyright 2006 Philips Consumer Electronics B.V. Eindhoven, The Netherlands
 All rights reserved. No part of this publication may be reproduced, stored in a retrieval system or transmitted, in any form or by any means, electronic, mechanical, photocopying, or otherwise without the prior permission of Philips.

Published by LX 0611 Service Audio Printed in The Netherlands Subject to modification

GB 3141 785 30750

Version 1.0



PHILIPS

HANDLING CHIP COMPONENTS

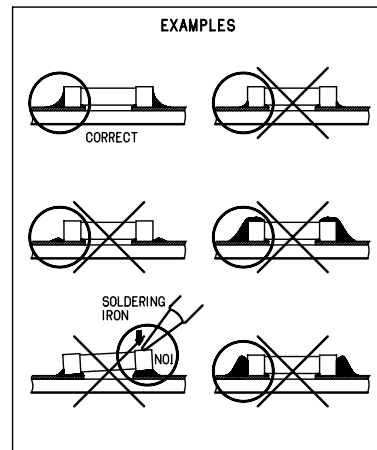
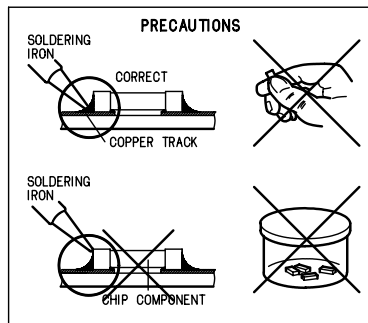
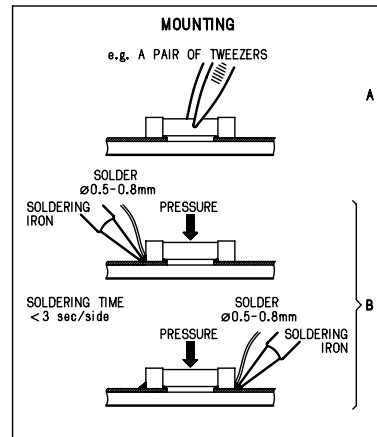
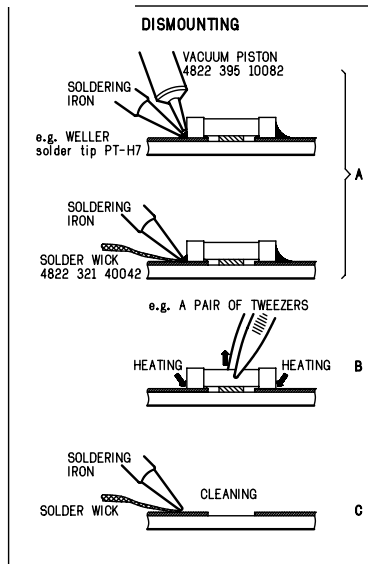
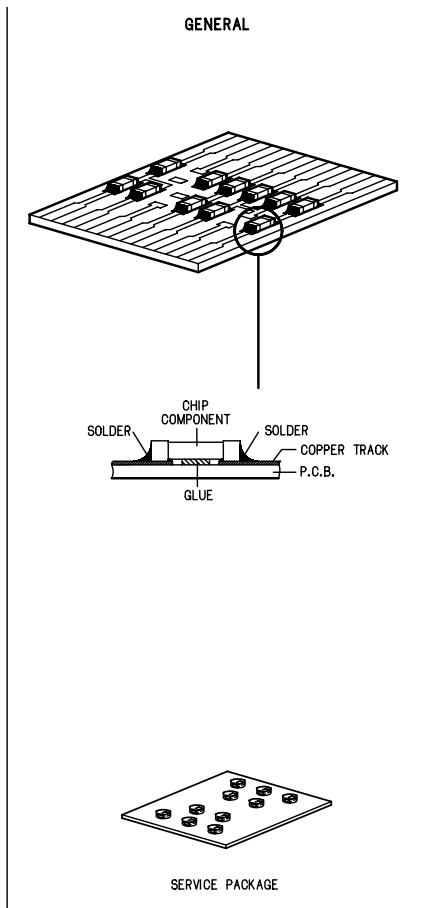

(GB) WARNING

All ICs and many other semiconductors are susceptible to electrostatic discharges (ESD). Careless handling during repair can reduce life drastically. When repairing, make sure that you are connected with the same potential as the mass of the set via a wristband with resistance. Keep components and tools at this potential.

ESD



(NL) WAARSCHUWING

Alle IC's en vele andere halfgeleiders zijn gevoelig voor electrostatische ontladingen (ESD). Onzorgvuldig behandelen tijdens reparatie kan de levensduur drastisch doen verminderen. Zorg ervoor dat u tijdens reparatie via een polsband met weerstand verbonden bent met hetzelfde potentiaal als de massa van het apparaat. Houd componenten en hulpmiddelen ook op ditzelfde potentiaal.

(F) ATTENTION

Tous les IC et beaucoup d'autres semi-conducteurs sont sensibles aux décharges statiques (ESD). Leur longévité pourrait être considérablement écourtée par le fait qu'aucune précaution n'est prise à leur manipulation. Lors de réparations, s'assurer de bien être relié au même potentiel que la masse de l'appareil et enfiler le bracelet sert d'une résistance de sécurité. Veiller à ce que les composants ainsi que les outils que l'on utilise soient également à ce potentiel.

(D) WARNUNG

Alle ICs und viele andere Halbleiter sind empfindlich gegenüber elektrostatischen Entladungen (ESD). Unvorsichtige Behandlung im Reparaturfall kann die Lebensdauer drastisch reduzieren. Sorgen Sie dafür, daß Sie im Reparaturfall über ein Pol-armband mit Widerstand mit dem Massepotential des Gerätes verbunden sind. Halten Sie Bauteile und Hilfsmittel ebenfalls auf diesem Potential.

(I) AVVERTIMENTO

Tutti IC e parecchi semi-conduttori sono sensibili alle scariche statiche (ESD). La loro longevità potrebbe essere fortemente ridatta in caso di non osservazione della più grande cauzione alla loro manipolazione. Durante le riparazioni occorre quindi essere collegato allo stesso potenziale che quello della massa dell'apparecchio tramite un braccialetto a resistenza. Assicurarsi che i componenti e anche gli utensili con quali si lavora siano anche a questo potenziale.

(GB)

Safety regulations require that the set be restored to its original condition and that parts which are identical with those specified be used. Safety components are marked by the symbol ▲

SAFETY



(F)

Les normes de sécurité exigent que l'appareil soit remis à l'état d'origine et que soient utilisées les pièces de rechange identiques à celles spécifiées. Les composants de sécurité sont marqués ▲

(D)

Bei jeder Reparatur sind die geltenden Sicherheitsvorschriften zu beachten. Der Originalzustand des Gerätes darf nicht verändert werden. Für Reparaturen sind Originalersatzteile zu verwenden. Sicherheitsbauteile sind durch das Symbol ▲ markiert.

(NL)

Veiligheidsbepalingen vereisen, dat het apparaat in zijn oorspronkelijke toestand wordt teruggebracht en dat onderdelen, identiek aan de gespecificeerde, worden toegepast. De Veiligheidsonderdelen zijn aangeduid met het symbool ▲

(I)

Le norme di sicurezza estigono che l'apparecchio venga rimesso nelle condizioni originali e che siano utilizzati i pezzi di ricambio identici a quelli specificati. Componenti di sicurezza sono marcati con ▲

(GB)

DANGER: Invisible laser radiation when open. AVOID DIRECT EXPOSURE TO BEAM.



(S)

Varning! Osynlig laserstrålning när apparaten är öppnad och spärrar är urkopplad. Betrakta ej strålen.

(DK)

Advarsel! Usynlig laserstrålning ved åbning når sikkerhedsafbrydere er ude af funktion. Undgå udsættelse for stråling.

(FIN)

Varoitus! Avatussa laitteessa ja suojalukituksen ohitettaessa olet alttiina näkymättömälle laserisäteilylle. Älä katso säteeseen!

(GB)

After servicing and before returning the set to customer perform a leakage current measurement test from all exposed metal parts to earth ground, to assure no shock hazard exists. The leakage current must not exceed 0.5mA.

(F)

"Pour votre sécurité, ces documents doivent être utilisés par des spécialistes agréés, seuls habilités à réparer votre appareil en panne".

INFORMATION ABOUT LEAD-FREE SOLDERING

Philips CE is producing lead-free sets from 1.1.2005 onwards.

IDENTIFICATION:

Regardless of special logo (not always indicated) one must treat all sets from 1 Jan 2005 onwards, according next rules:



Example S/N:



Bottom line of typeplate gives a 14-digit S/N. Digit 5&6 is the year, digit 7&8 is the week number, so in this case 2005 wk12

So from 0501 onwards = from 1 Jan 2005 onwards

Important note: In fact also products of year 2004 must be treated in this way as long as you avoid mixing solder-alloys (leaded/lead -free). So best to always use SAC305 and the higher temperatures belong to this.

Due to lead-free technology some rules have to be respected by the workshop during a repair:

- Use only lead-free solder alloy Philips SAC305 with order code 0622 149 00106. If lead-free solder-paste is required, please contact the manufacturer of your solder-equipment. In general use of solder-paste within workshops should be avoided because paste is not easy to store and to handle.
- Use only adequate solder tools applicable for lead-free solder alloy. The solder tool must be able
 - To reach at least a solder-temperature of 400°C,
 - To stabilize the adjusted temperature at the solder-tip
 - To exchange solder-tips for different applications.
- Adjust your solder tool so that a temperature around 360°C – 380°C is reached and stabilized at the solder joint. Heating-time of the solder-joint should not exceed ~ 4 sec. Avoid temperatures above 400°C otherwise wear-out of tips will rise drastically and flux-fluid will be destroyed. To avoid wear-out of tips switch off un-used equipment, or reduce heat.
- Mix of lead-free solder alloy / parts with leaded solder alloy / parts is possible but PHILIPS recommends strongly to avoid mixed solder alloy types (leaded and lead-free).
If one cannot avoid or does not know whether product is lead-free, clean carefully the solder-joint from old solder alloy and re-solder with new solder alloy (SAC305).
- Use only original spare-parts listed in the Service-Manuals. Not listed standard-material (commodities) has to be purchased at external companies.
- Special information for BGA-ICs:
 - always use the 12nc-recognizable soldering temperature profile of the specific BGA (for de-soldering always use the lead-free temperature profile, in case of doubt)
 - lead free BGA-ICs will be delivered in so-called 'dry-packaging' (sealed pack including a silica gel pack) to protect the IC against moisture. After opening, dependent of MSL-level seen on indicator-label in the bag, the BGA-IC possibly still has to be baked dry. (MSL=Moisture Sensitivity Level). This will be communicated via AYS-website. Do not re-use BGAs at all.
- For sets produced before 1.1.2005 (except products of 2004), containing leaded solder-alloy and components, all needed spare-parts will be available till the end of the service-period. For repair of such sets nothing changes.
- On our website www.atyourservice.ce.Philips.com you find more information to:
 - * BGA-de-/soldering (+ baking instructions)
 - * Heating-profiles of BGAs and other ICs used in Philips-sets

You will find this and more technical information within the "magazine", chapter "workshop news".

For additional questions please contact your local repair-helpdesk.

SERVICE INSTRUCTION

Safety regulations require that after a repair, the set must be returned in its original condition. Pay in particular attention to the following points:

- Route the wire trees correctly and fix them with the mounted cable clamps.
- Check the insulation of the AC Power lead for external damage.
- Check the strain relief of the AC Power cord for proper function.
- Check the electrical DC resistance between the AC Power Plug and the secondary side (only for sets which have a AC Power isolated power supply):
 1. Unplug the AC Power cord and connect a wire between the two pins of the AC Power plug.
 2. Set the AC Power switch to the "on" position (keep the AC Power cord unplugged!).
 3. Measure the resistance value between the pins of the AC Power plug and the metal shielding of the tuner or the aerial connection on the set. The reading should be larger than 4.5 Mohm (For U.S. it should be between 4.2 Mohm and 12 Mohm).
 4. Switch "off" the set, and remove the wire between the two pins of the AC Power plug.
- Check the cabinet for defects, to avoid touching of any inner parts by the customer.

TECHNICAL SPECIFICATIONS

GENERAL

Mains voltage	-/98 : 120/230V
Mains frequency	-/98 : 50/60 Hz
Battery	remote : R06 (AA)
Power consumption	normal : < 45 W
	Standby : < 7 W
Dimension (W x H x D)	: 265 x 300 x 254 mm
Weight	: 6.5 / 4 Kg
(with/without speaker)	

AMPLIFIER

Output power	: 2 x 10 W
Speaker impedance	: 2 x 6 ohm
Frequency response	: 63 Hz - 16 kHz (± 3 dB)
Signal to Noise ratio	: > 62 dBA

TUNER - FM SECTION

Tuning range	: 87.5 - 108 MHz
IF frequency	: 10.7 MHz \pm 0.02 MHz
Sensitivity	: < 22 dBf at 26 dB
Selectivity	300kHz : < 49 dB
IF Rejection	: > 40 dB
Image Rejection	: > 18dB
Distortion	: < 6 %
Tuning Grid	: 50K Hz

TUNER - AM SECTION

Tuning range	: 522 - 1611 kHz
Tuning Grid	: 9K Hz
IF frequency	: 455 kHz \pm 3 kHz
Sensitivity	: \leq 4 mV/m 26 dB
Selectivity S9/300kHz	: > 16 dB
IF rejection	: > 24 dB
Distortion	: < 7%
Image rejection	: > 28 dB

AUDIO CASSETTE RECORDER

Number of tracks	: 2 stereo
Tape speed	: 4.7 cm/sec +3/-3%
Wow & flutter	: < 0.4 % DIN
Fast wind/rewind C60	: 160 sec.
Frequency response	P/B : 80 - 12500 Hz
S/N ratio	: 48 dBA

VIDEO PERFORMANCE

Number of programmable track	: 20
Channel separation	1 kHz : \geq 25 dB
S/N ratio	: \geq 62 dBA
Frequency response	: 63 -16000Hz
MPEG1	: VCD version 2.0
MPEG1 Layer 3	: MPEG AUDIO
MP3-CD bit rate	: 32 - 256 kbps

SERVICE TOOLS

Audio signal disc SBC 429.....	4822 397 30184
Playability test disc SBC 444.....	4822 397 30245
Test disc 5 (disc without errors) +	
Test disc 5A (disc with dropout errors, black spots and fingerprints)	
SBC 426/426A.....	4822 397 30096
Burn in test disc (65 min. 1kHz signal at -30 dB level without "pause").....	4822 397 30155

AVAILABLE ESD PROTECTION EQUIPMENT

anti-static table mat	large 1200x650x1.25mm	4822 466 10953
	small 600x650x1.25m	4822 466 10958
anti-static wristband		4822 395 10223
connection box (3 press stud connections, 1M Ω)		4822 320 11307
extendible cable (2m, 2M Ω , to connect wristband to connection box)		4822 320 11305
connecting cable (3m, 2M Ω , to connect table mat to connection box)		4822 320 11306
earth cable (1M Ω , to connect any product to mat or to connection box)		4822 320 11308
KIT ESD3 (combining all 6 prior products - small table mat)		4822 310 10671
wristband tester		4822 344 13999

SERVICE MEASUREMENT

Tuner SW

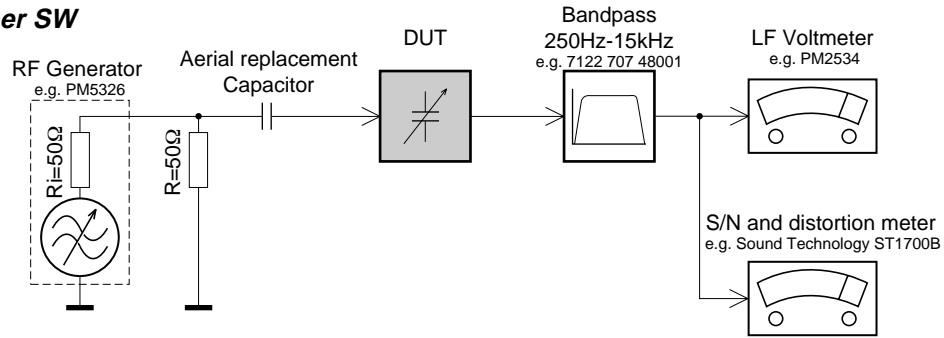

To avoid atmospheric interference all AM-measurements have to be carried out in a Faraday's cage. Use a bandpass filter (or at least a high pass filter with 250Hz) to eliminate hum (50Hz, 100Hz).

Tuner AM (MW,LW)

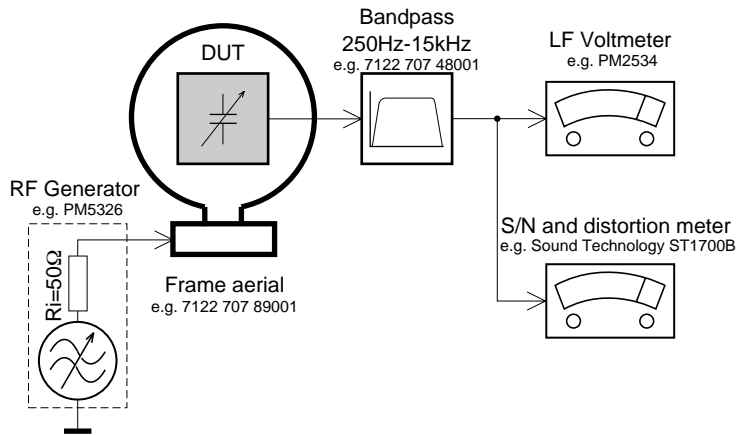

To avoid atmospheric interference all AM-measurements have to be carried out in a Faraday's cage.

CD

Use Audio Signal Disc SBC429 4822 397 30184 (replaces test disc 3)
L.P.F. = 13th order filter 4822 395 30204

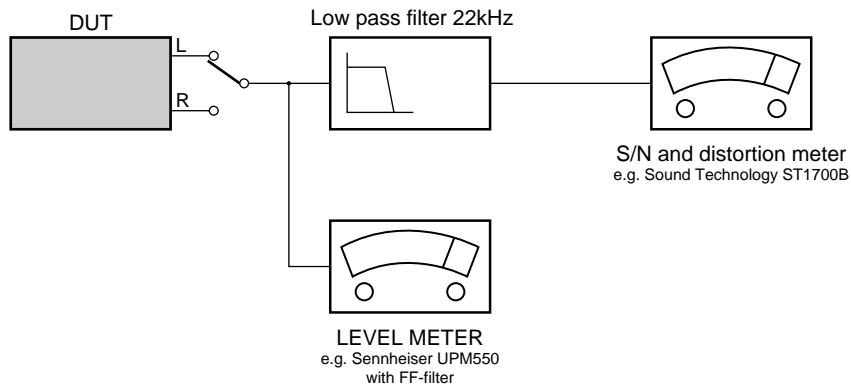

CONNECTION AND CONTROLS

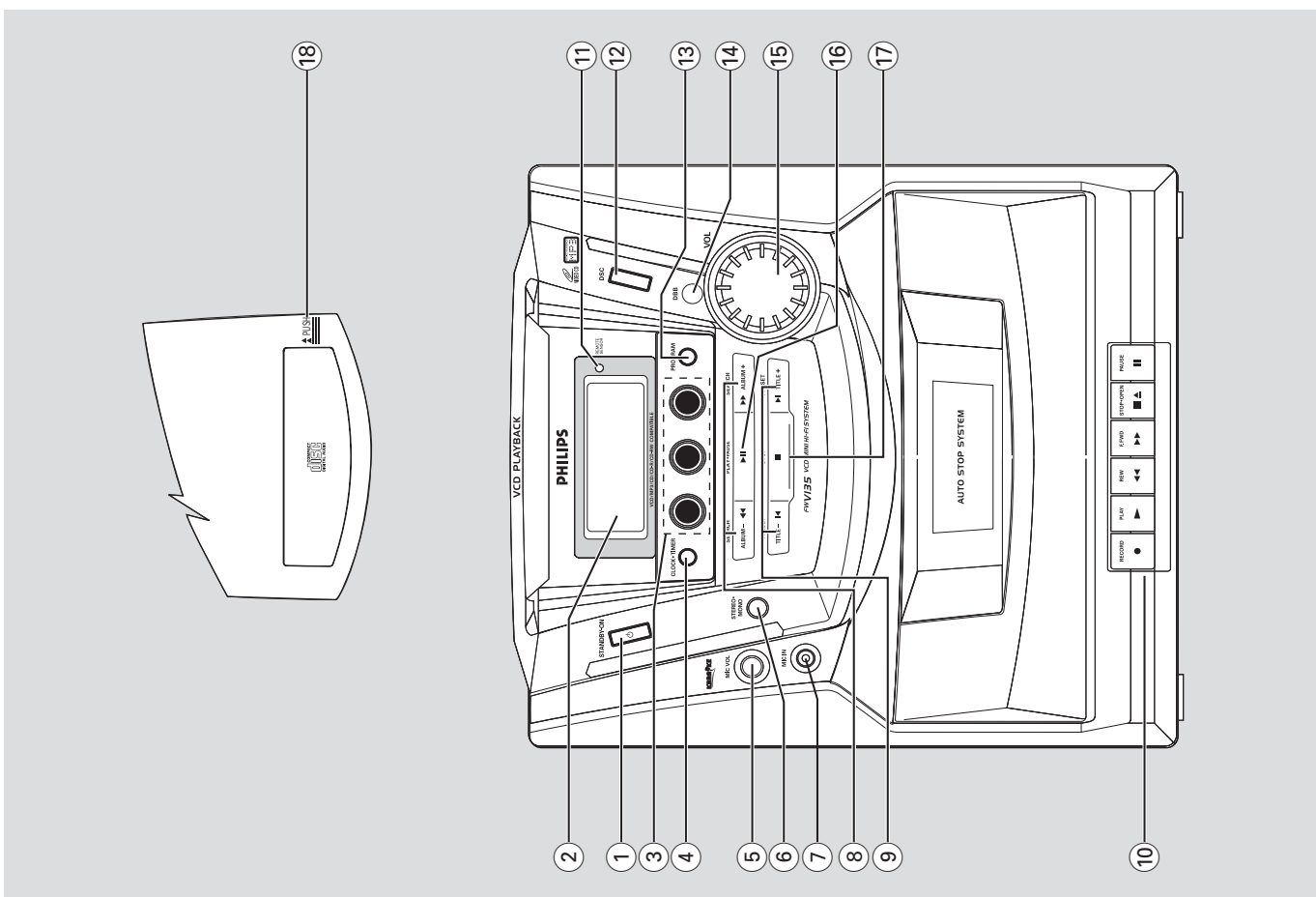
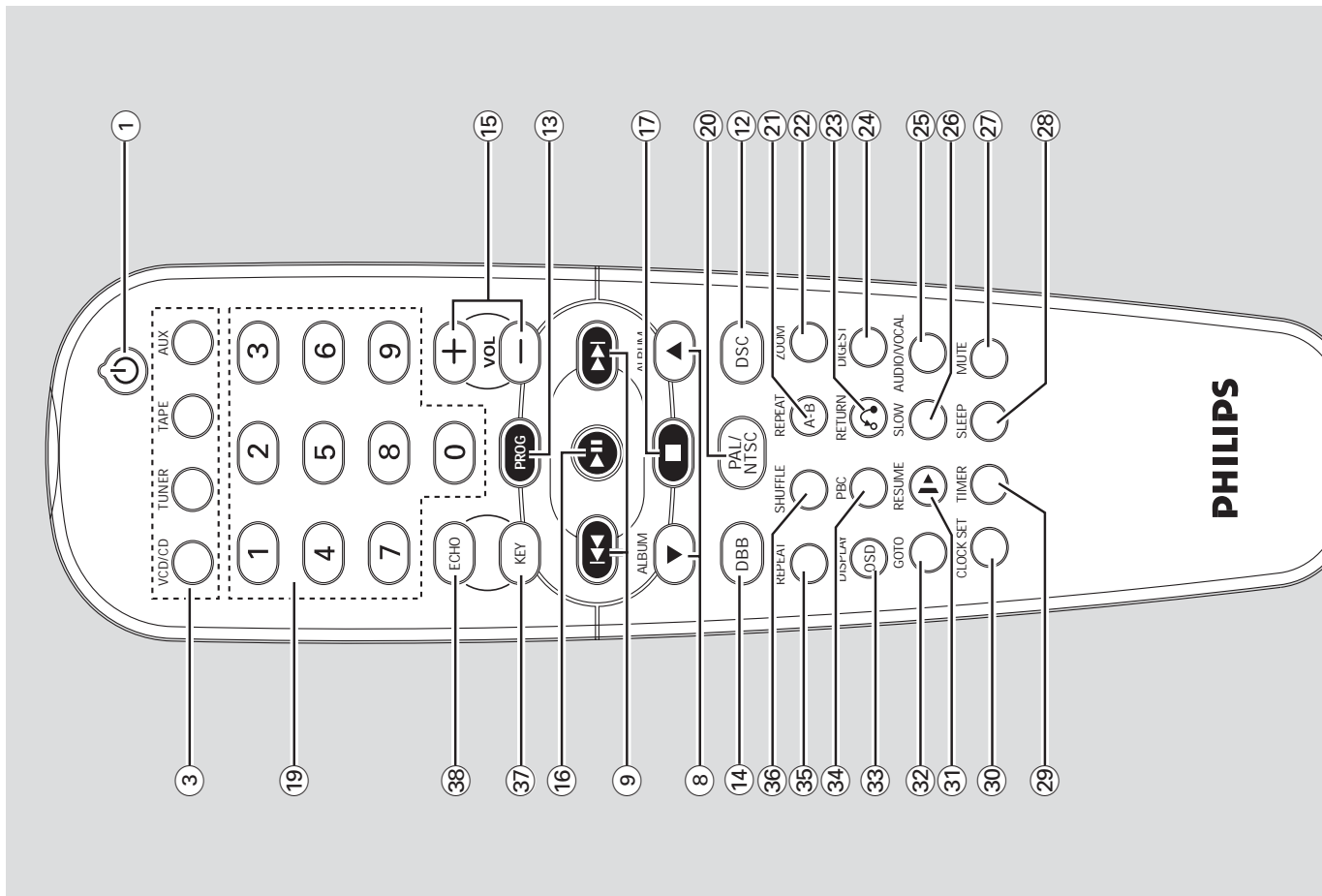

CONNECTION AND CONTROLS

Controls

Controls (main set's illustration on page 3&4)

Controls on the system and remote control

- ① **STANDBY ON**
 - Switches the system on or to standby mode.
- ② **Display screen**
 - Views the current status of the system.
- ③ **Source mode**
 - Selects VCD/CD, TUNER, TAPE or AUX.
- ④ **CLOCK-TIMER**
 - Enters clock setting mode.
 - Sets and activates wake-up timer.
- ⑤ **MIC VOL**
 - Adjusts the mixing level for Karaoke.
- ⑥ **STEREO-MONO**
 - for Tuner.....Switches between stereo and mono sound in FM band.
- ⑦ **MIC IN**
 - Connects a microphone.
- ⑧ **ALBUM-/+ <<|>|>> / SEARCH (ALBUM <|>)**
 - for MP3-CD.....Selects previous/next album.
 - for Audio CD.....Fast reverse/forward the disc.
 - for VCD.....Fast reverse/forward the disc.
 - (The system's **ALBUM-/+ <<|>|>>** / **>>> / SEARCH** buttons only)
 - for Tuner.....Tunes to a radio station (The system's **ALBUM-/+ <<|>|>>** / **SEARCH** buttons only)
- Adjusts the hours for the clock/timer functions.
- ⑨ **TITLE-/+ <|>|>> / PRESET (<<<|>|>>)**
 - for Disc.....Selects a desired track
 - for VCD.....Fast reverse/forward the disc.
 - (The remote's **<<<|>|>>** / **>>>** buttons only)
- for Tuner.....Selects a preset radio station.
- Adjusts the minutes for the clock/timer functions.
- ⑩ **Tape deck operations**
 - RECORD**Starts recording
 - PLAY**Starts playback.
 - REW** / **F. FWD**
 -Fast rewinds/ winds the tape.

- ⑭ **DIGEST**
 - Scans through a VCD or its specific track.
- ⑮ **AUDIO/VOCAL**
 - Fades out the original vocal from a Karaoke VCD or switches between mono or stereo mode during audio disc playback.
 - Selects channel left / channel right / stereo sound, or selects a language in a bilingual VCD.
- ⑯ **SLOW**
 - Watches the VCD at a slower speed.
- ⑰ **MUTE**
 - Mutes or restores sound.
- ⑱ **SLEEP**
 - Activates/ deactivates or sets sleep timer
- ⑲ **TIMER**
 - Sets and activates the wake-up timer
- ⑳ **CLOCK SET**
 - Enters clock setting mode
- ㉑ **RESUME**
 - Continues VCD playback again from where you have stopped
- ㉒ **GOTO**
 - starts playback at any chosen time on the disc (for CD/VCD operation only and PBC mode is off).
- ㉓ **DISPLAY (OSD)**
 - For VCDs: displays the disc information.
- ㉔ **PBC (Playback Control)**
 - Switches on or off the PBC mode (for VCD 2.0 only)
- ㉕ **REPEAT**
 - Repeats a track / CD program / entire disc.
- ㉖ **SHUFFLE**
 - Plays tracks in a random order.

- ㉗ **STOP-OPEN** /
 - Stops the tape; opens the tape compartment.
- ㉘ **PAUSE II**
 - Interrupts recording or playback.
- ㉙ **REMOTE SENSOR**
 - Infrared sensor for remote control.
- ㉚ **DSC (Digital Sound Control)** (Digital Sound Control)
 - Selects sound characteristics: POP/ JAZZ/ ROCK/ OPTIMAL.
- ㉛ **PROGRAM (PROG)**
 - for VCD/CD/MP3-CD.....Programs disc tracks for Tuner Programs preset radio stations.
- ㉜ **DBB (Dynamic Bass Boost)**
 - Enhances the bass
- ㉝ **VOL (VOL+ / -)**
 - Increases or decreases the volume.
- ㉞ **PLAY-PAUSE**
 - for Disc.....Starts or interrupts playback.
- ㉟ **STOP**
 - for VCD/CD/MP3-CD.....Stops playback or to clears a program.
- ㊱ **PUSH**
 - Opens or closes the disc tray.
- ㊲ **DIGIT 0 - 9**
 - for CD/VCD/MP3-CD - Select a track number. (numbers consisting more than 2 figures must be keyed in within 2 seconds)
- ㊳ **PAL/NTSC**
 - For Disc.....Press and hold to select PAL or NTSC for clear disc viewing on TV screen.
- ㊴ **REPEAT A · B**
 - Plays a certain scene or passage of a CD/VCD repeatedly (REPEAT A - B is not possible for MP3-CD).
- ㊵ **ZOOM**
 - For Disc.....Enlarges a picture or active image on TV screen.
- ㊶ **RETURN**
 - Returns to the previous MENU level during VCD playback (with PBC on for VCD with PBC)

- ㊷ **KEY**
 - Changes the VCD key tone level to suit your vocal range.

- ㊸ **ECHO**
 - Adjusts the VCD echo level for Karaoke after inserting the microphone.

Notes for remote control:

- First, select the source you wish to control by pressing one of the source select keys on the remote control (VCD/ CD or TUNER, for example).
- Then select the desired function (, / for example).

Cleaning the Cabinet

Use a soft cloth slightly moistened with a mild detergent solution. Do not use a solution containing alcohol, spirits, ammonia or abrasives.

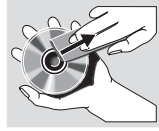

Cleaning Discs

When a disc becomes dirty, clean it with a cleaning cloth. Wipe the disc from the centre out.

Do not use solvents such as benzene, thinner, commercially available cleaners, or antistatic spray intended for analogue records.

Cleaning the disc lens

After prolonged use, dirt or dust may accumulate at the disc lens. To ensure good playback quality, clean the disc lens with Philips CD Lens Cleaner or any commercially available cleaner. Follow the instructions supplied with cleaner.

Cleaning the Heads and the Tape Paths

To ensure good recording and playback quality clean the heads (A), the capstan(s) (B), and pressure roller(s) (C) after every 50 hours of tape operation.

Caution: Do not rotate the heads during cleaning.

Use a cotton swab slightly moistened with cleaning fluid or alcohol. You can also clean the heads by playing a cleaning tape once.

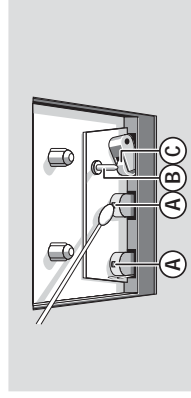

Demagnetising the heads

Use a demagnetising tape available at your dealer.

Troubleshooting

WARNING

Under no circumstances should you try to repair the system yourself, as this will invalidate the warranty. Do not open the system as there is a risk of electric shock.

If a fault occurs, first check the points listed below before taking the system for repair. If you are unable to remedy a problem by following these hints, consult your dealer or Philips for help.

Troubleshooting

Problem	Solution
Radio reception is poor.	If the signal is too weak, adjust the antenna or connect an external antenna for better reception. Increase the distance between the Mini HiFi System and your TV or VCR.
Recording or playback cannot be made.	Clean deck parts, see "Maintenance". Use only normal (IEC I) tape for recording.
The system does not react when buttons are pressed.	Remove and reconnect the AC power plug and switch on the system again.
Sound cannot be heard or is of poor quality.	Adjust the volume. Check that the speakers are connected correctly. Check if the stripped speaker wire is clamped.
The left and right sound outputs are reversed.	Check the speaker connections and location.
The remote control does not function properly.	Select the source (CD or TUNER, for example) before pressing the function button (▶◀, ◀▶ / ▶▶◀◀). Reduce the distance between the remote control and the system. Insert the battery with its polarities (+/- signs) aligned as indicated. Replace the battery. Point the remote control directly toward REMOTE SENSOR sensor on the front of the system.
The wake-up timer is not working.	Set the clock correctly. If a recording is in progress, stop the recording.
The Clock/Timer setting is erased.	Power has been interrupted or the power cord has been disconnected. Reset the clock/timer.

Problem

"NO DISC" is displayed.

Solution

Insert a disc.
Check if the disc is inserted upside down.
Wait until the moisture condensation at the lens has cleared.
Replace or clean the disc, see "Maintenance".
Use a finalised CD-RW or CD-R.
Connect the cable between the system and TV.
Change the system to the respective PAL or NTSC setting.

No picture on TV screen.

No colour on TV.

DISASSEMBLY DIAGRAM

- A Remove the Back Cabinet :
 A1 Remove screws M3x8 - 7pcs
 A2 Remove screws M3x24 - 5pcs

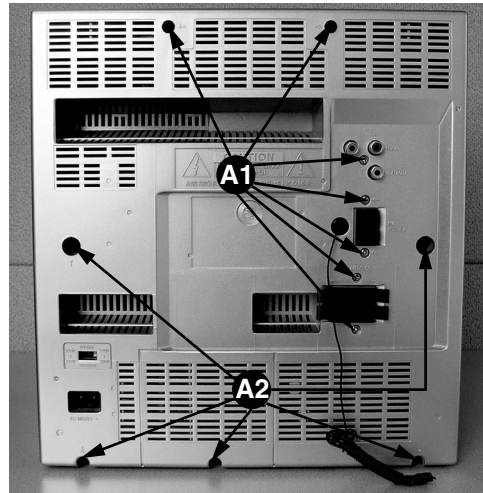

- B Remove the VCD Loader :
 B Remove screws M3 x12 - 2pcs

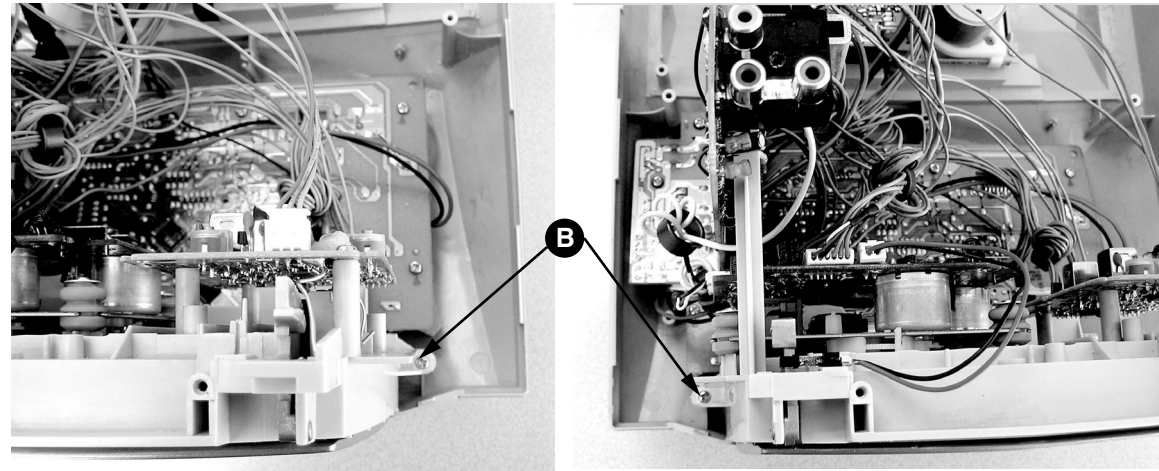

- C Remove the VCD Board and Tuner board :
 C1 Remove screws TP2.6x10 - 4pcs
 C2 Remove screws M3x8 - 2pcs

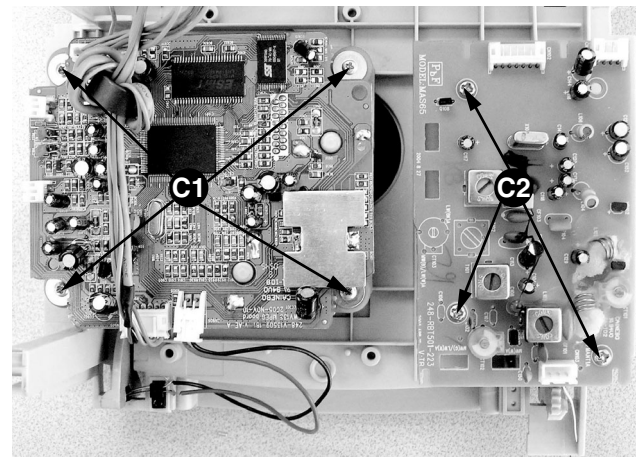

- D Remove the Audio board :
 D Remove screws M3x8 - 2pcs

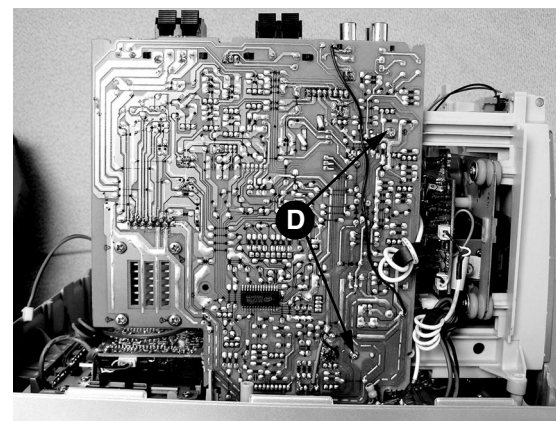

- E Remove the VFD and Mic Jack board :
 E1 Remove screws M3 x10 - 3pcs
 E2 Remove screws M3x8 - 3pcs

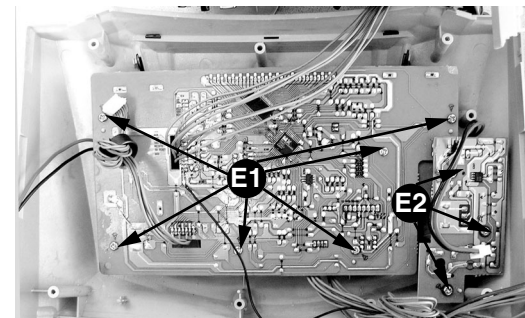

- F Remove the Recording board :
 F Remove screws M3 x10 - 3pcs

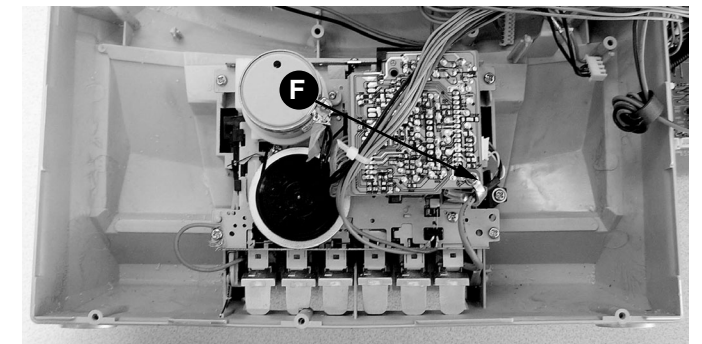

DISASSEMBLY DIAGRAM

G Remove the Cassette Deck :
G Remove screws M3x10 - 5pcs

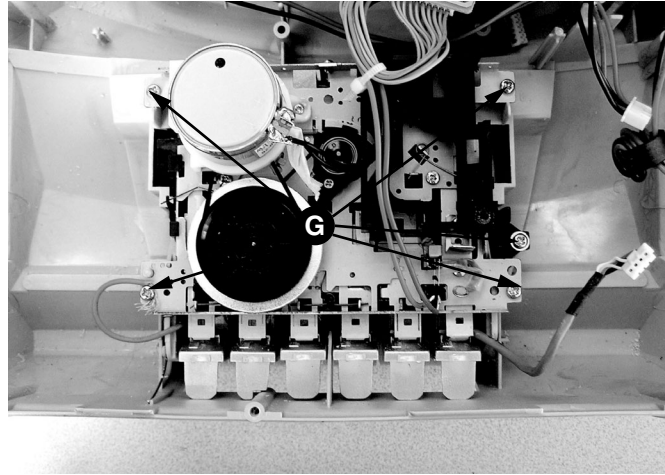

H Remove the pannel
Remove screws M3x8 - 3pcs

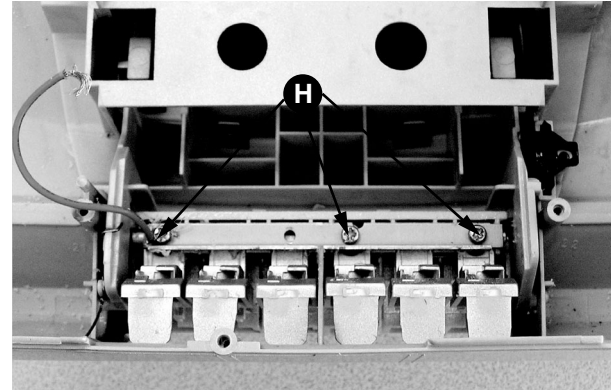

I Remove the Cassette Door cover as shown in the diagram below.

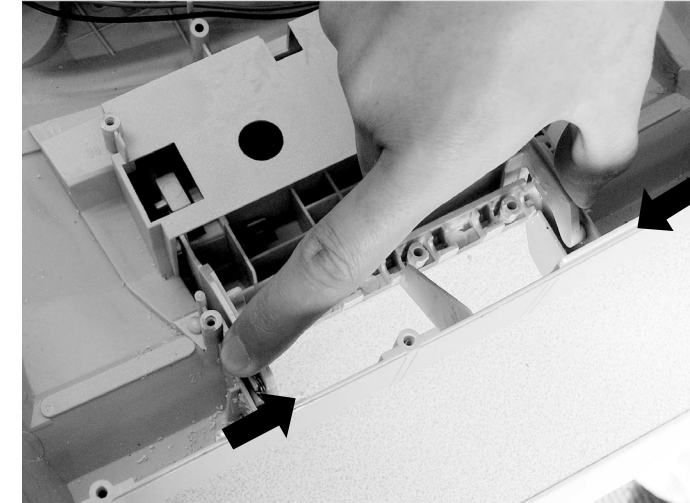

J Remove the CD Door :
J1 Remove screws M2x4 - 1pc
J2 Remove the leaf switch

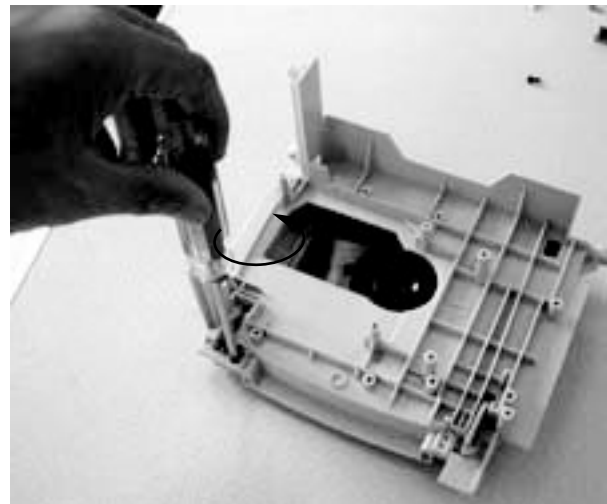

J3 Remove the CD Door as indicated.

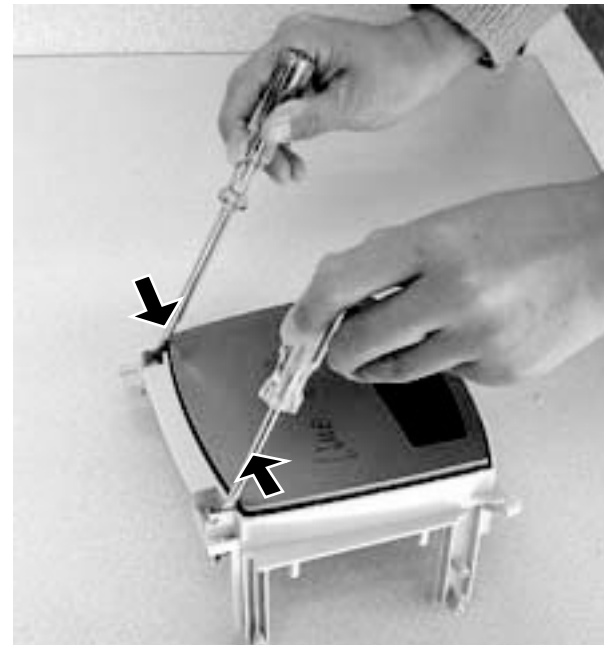

SET BLOCK DIAGRAM

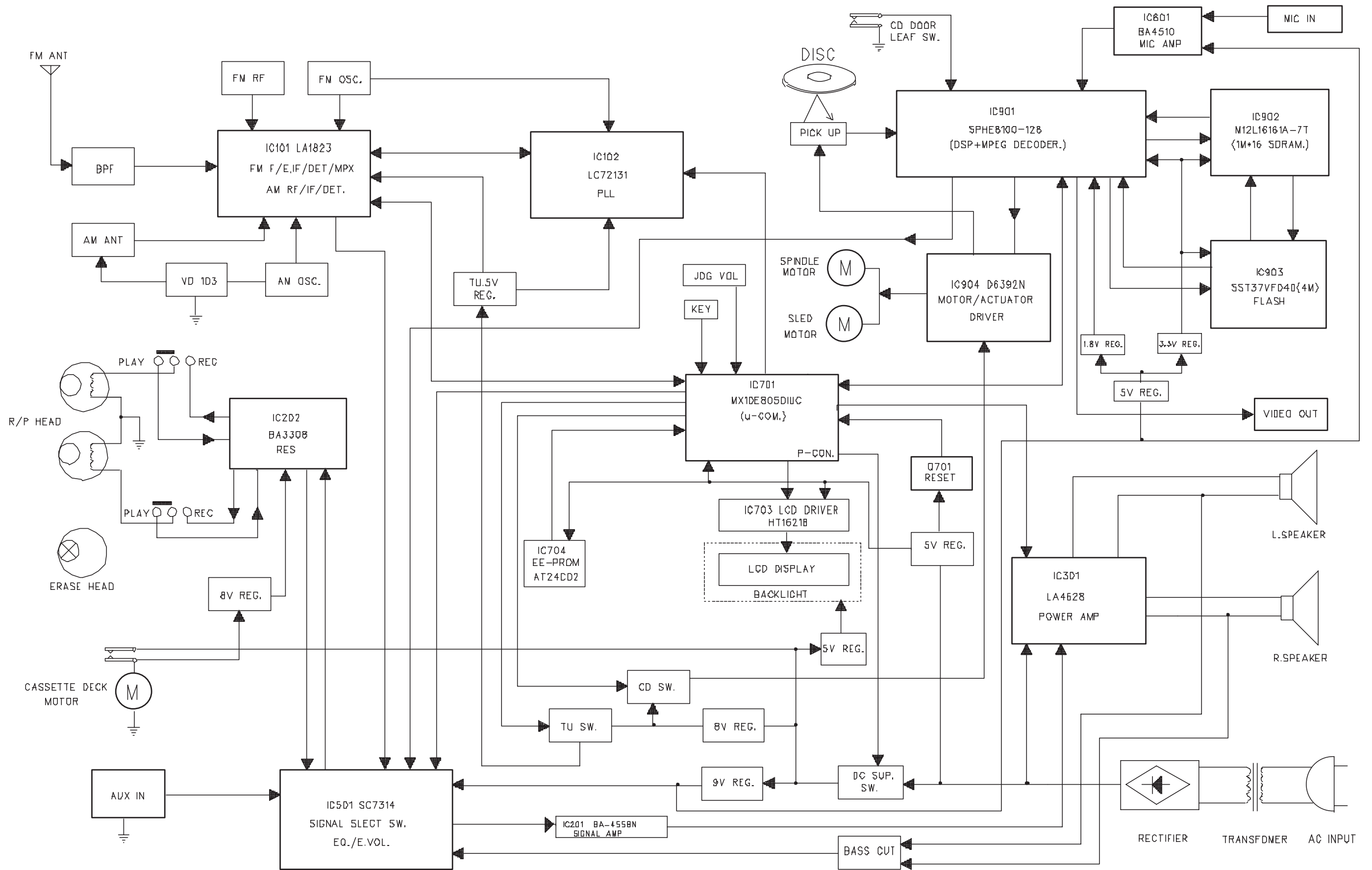

SET WIRING DIAGRAM

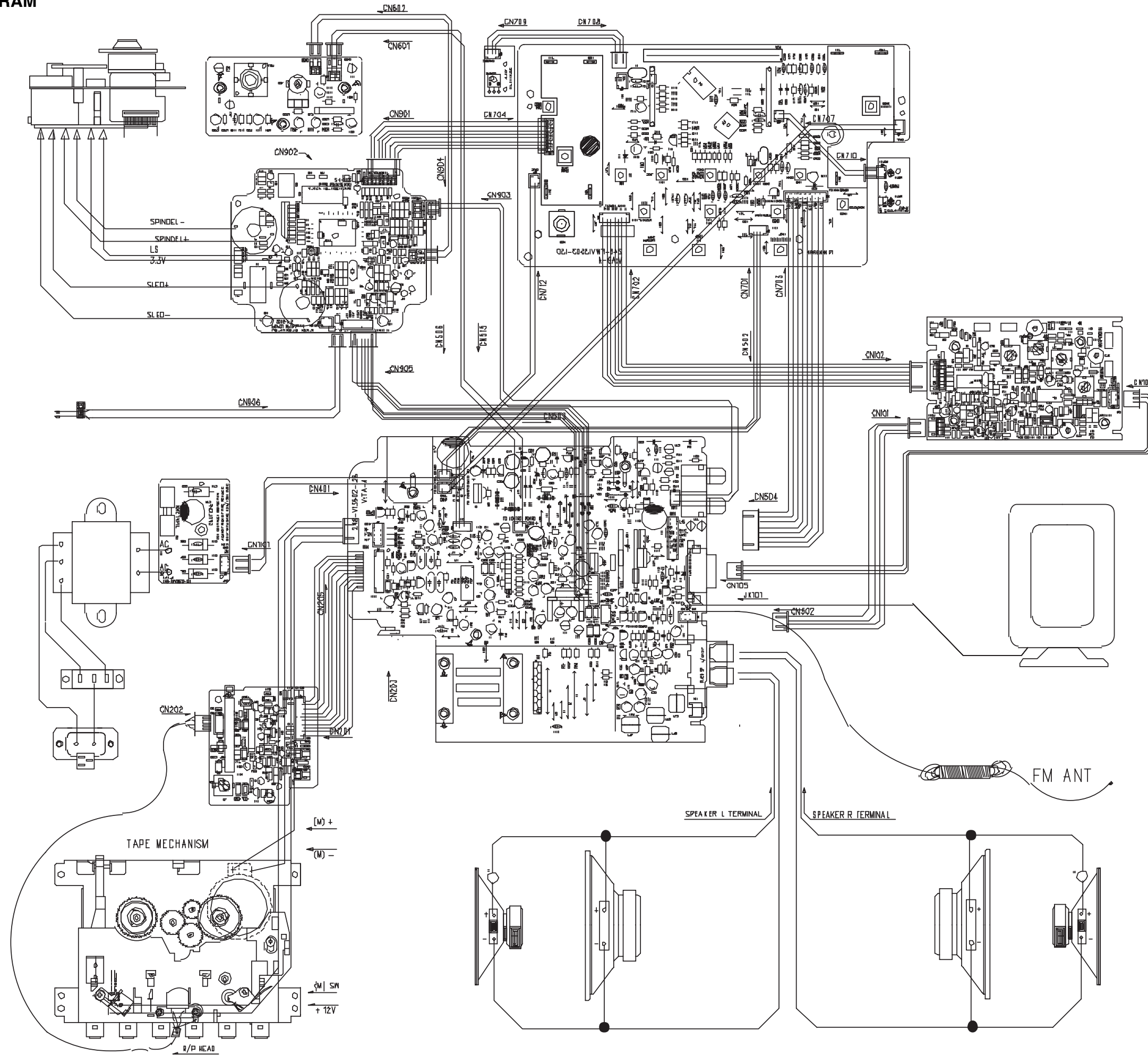

CIRCUIT DIAGRAM - TUNER BOARD

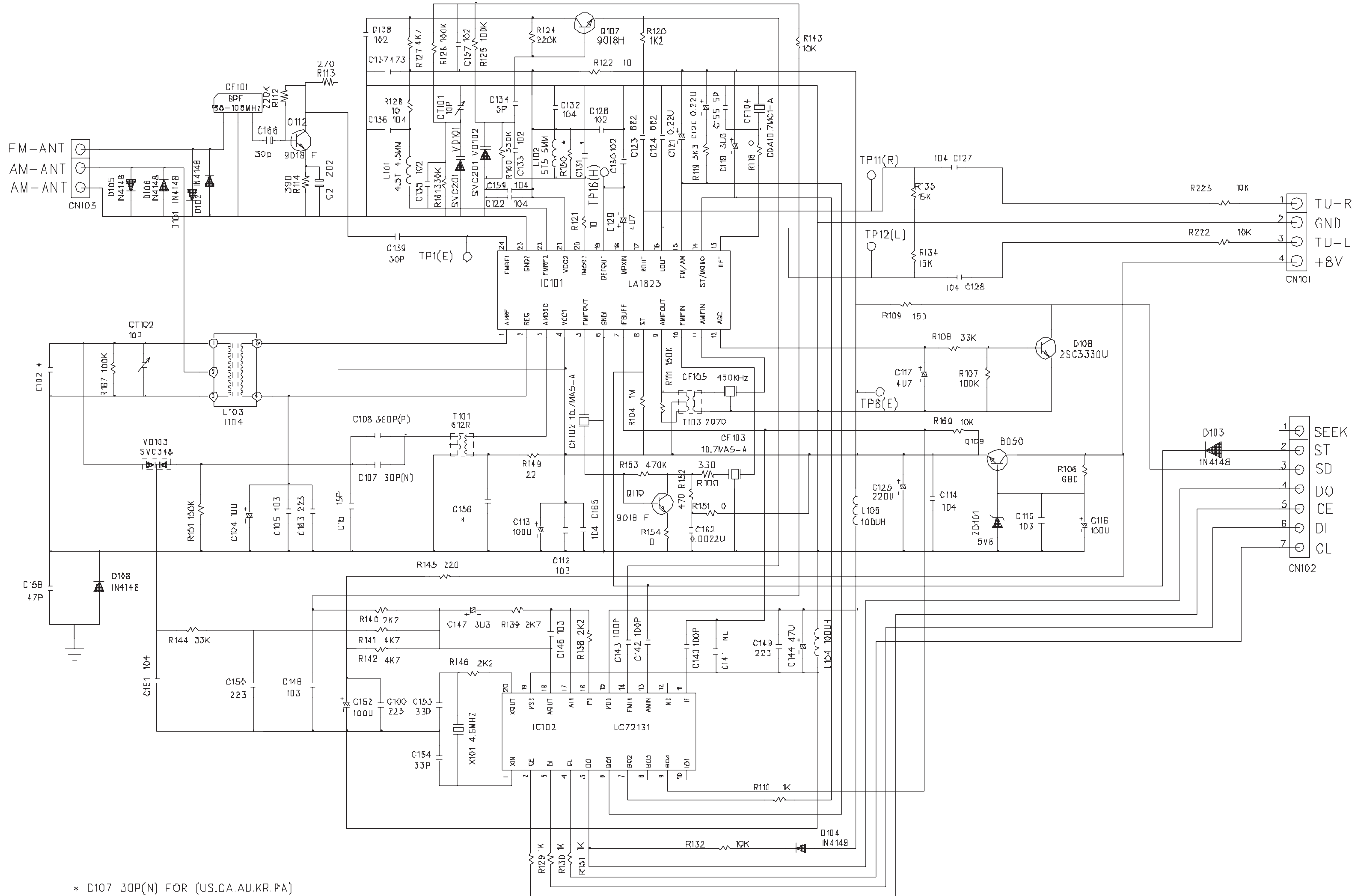

* C107 30P(N) FOR (US.CA.AU.KR.PA)
 * C160.C161(0.222U) AND R150(4.7K DHM) FOR FCC(US.CA)

CIRCUIT DIAGRAM - TUNER BOARD

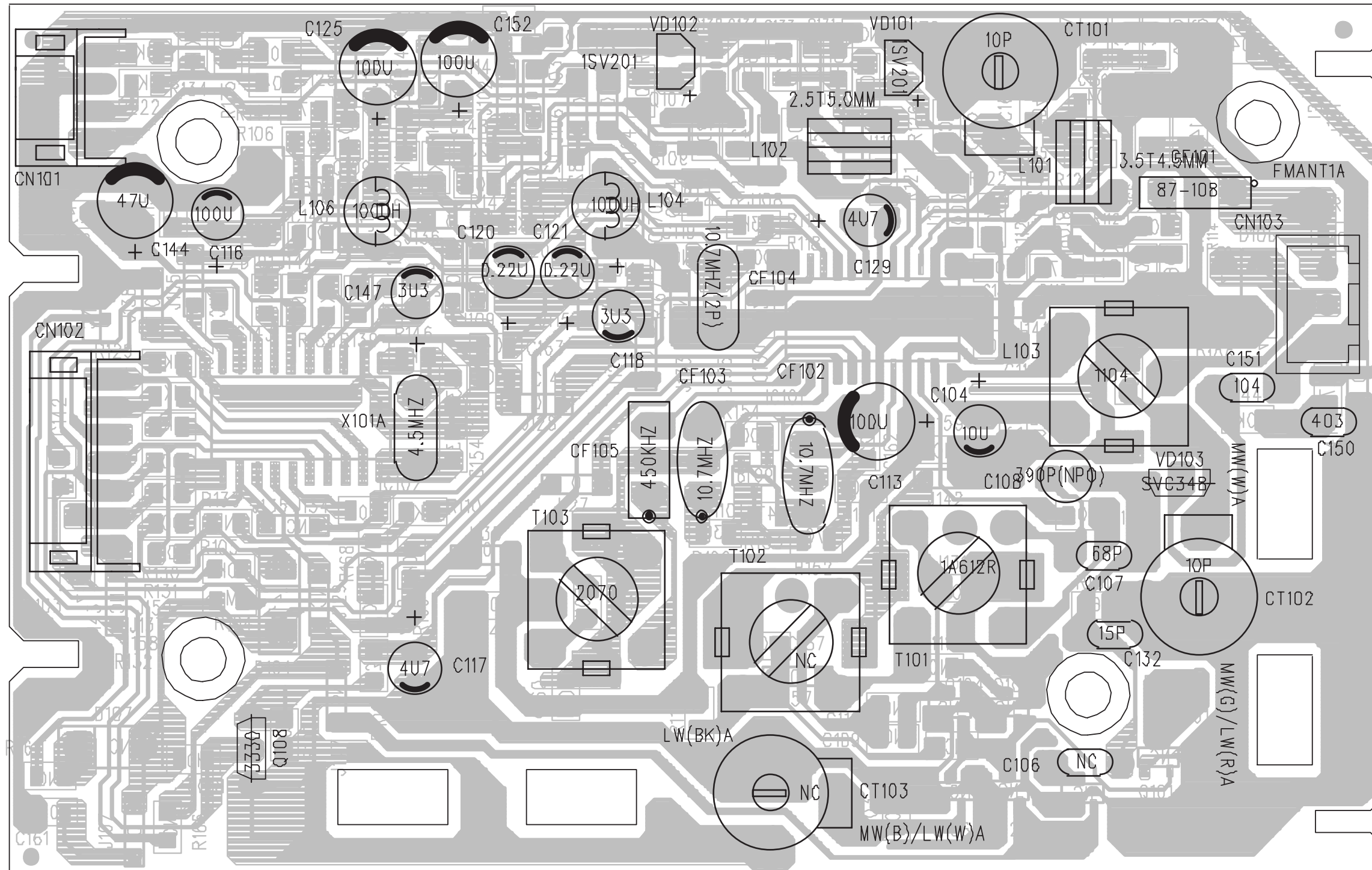

LAYOUT DIAGRAM - TUNER BOARD

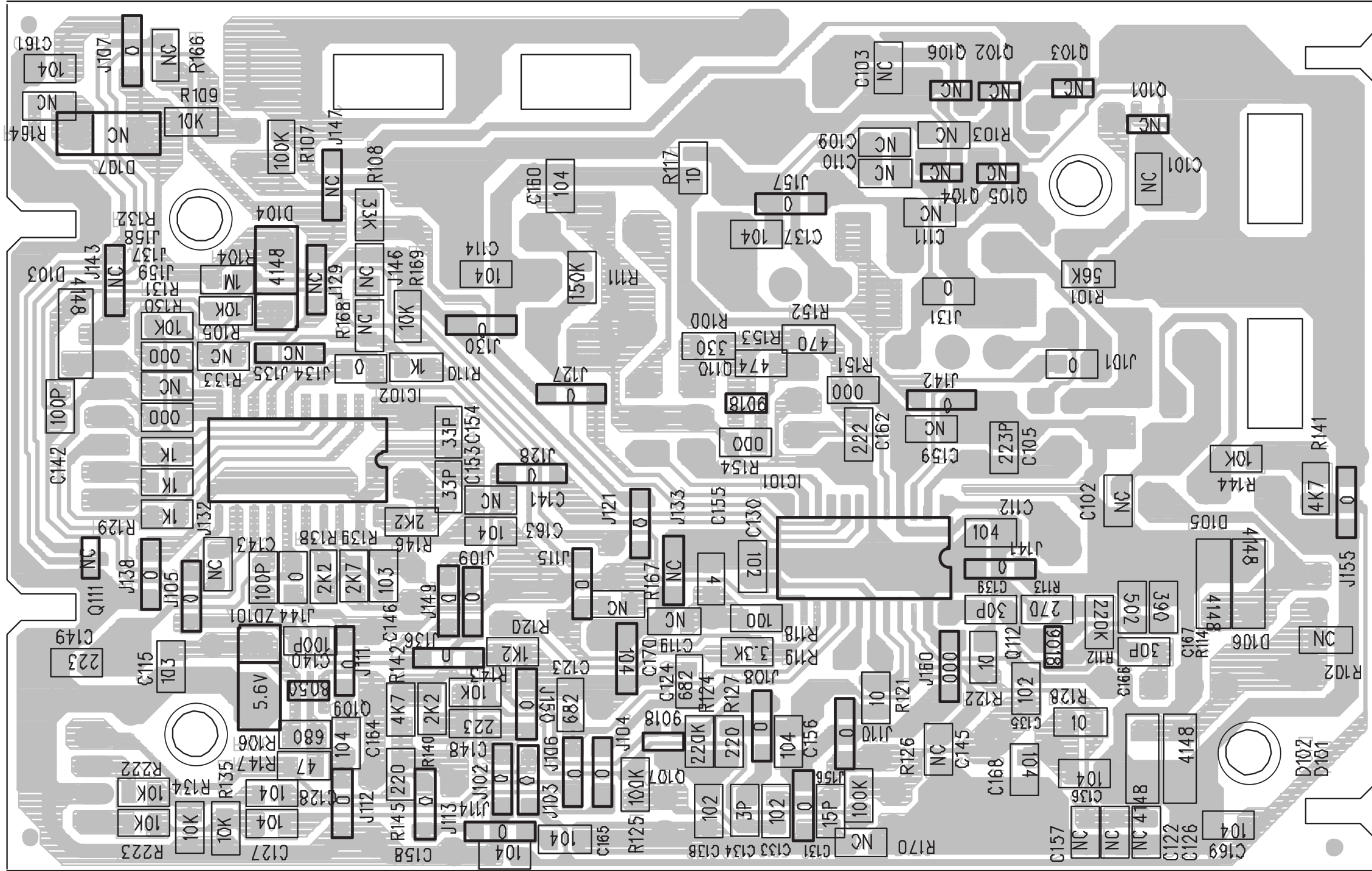

CIRCUIT DIAGRAM - AUDIO BOARD

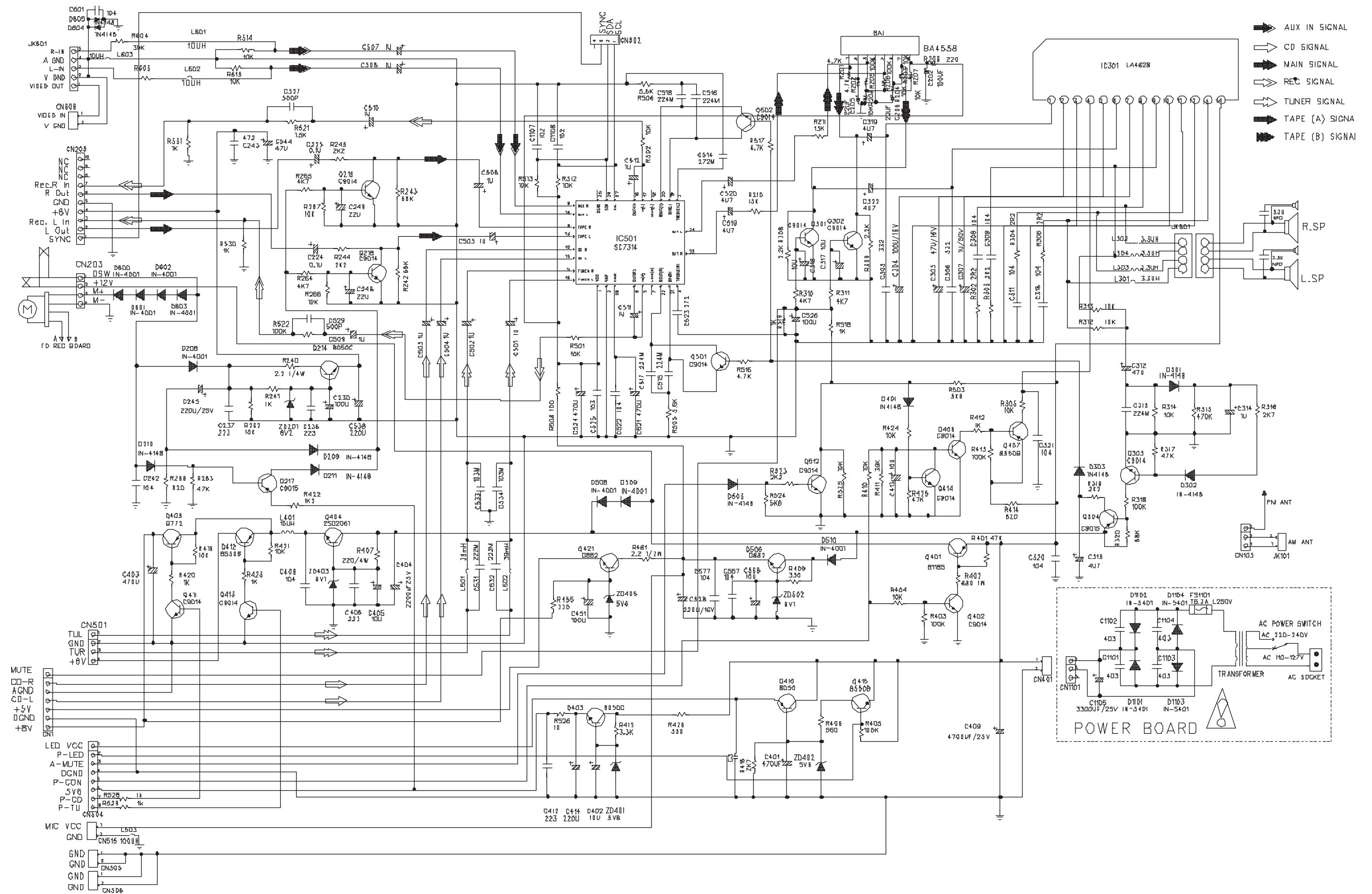

- ➡ AUX IN SIGNAL
- ➡ CD SIGNAL
- ➡ MAIN SIGNAL
- ➡ REC SIGNAL
- ➡ TUNER SIGNAL
- ➡ TAPE (A) SIGNAL
- ➡ TAPE (B) SIGNAL

POWER BOARD

AC POWER SWITCH
AC 220-240V
AC 110-127V
TR ANSGRFORMER
AC SOCKET

C1101 3300uF/25V
D1101 IN-5401
D1102 IN-5401
D1103 IN-5401
D1104 FS1101
C1102 403
C1103 403
C1104 403
L250V

LAYOUT DIAGRAM - AUDIO BOARD

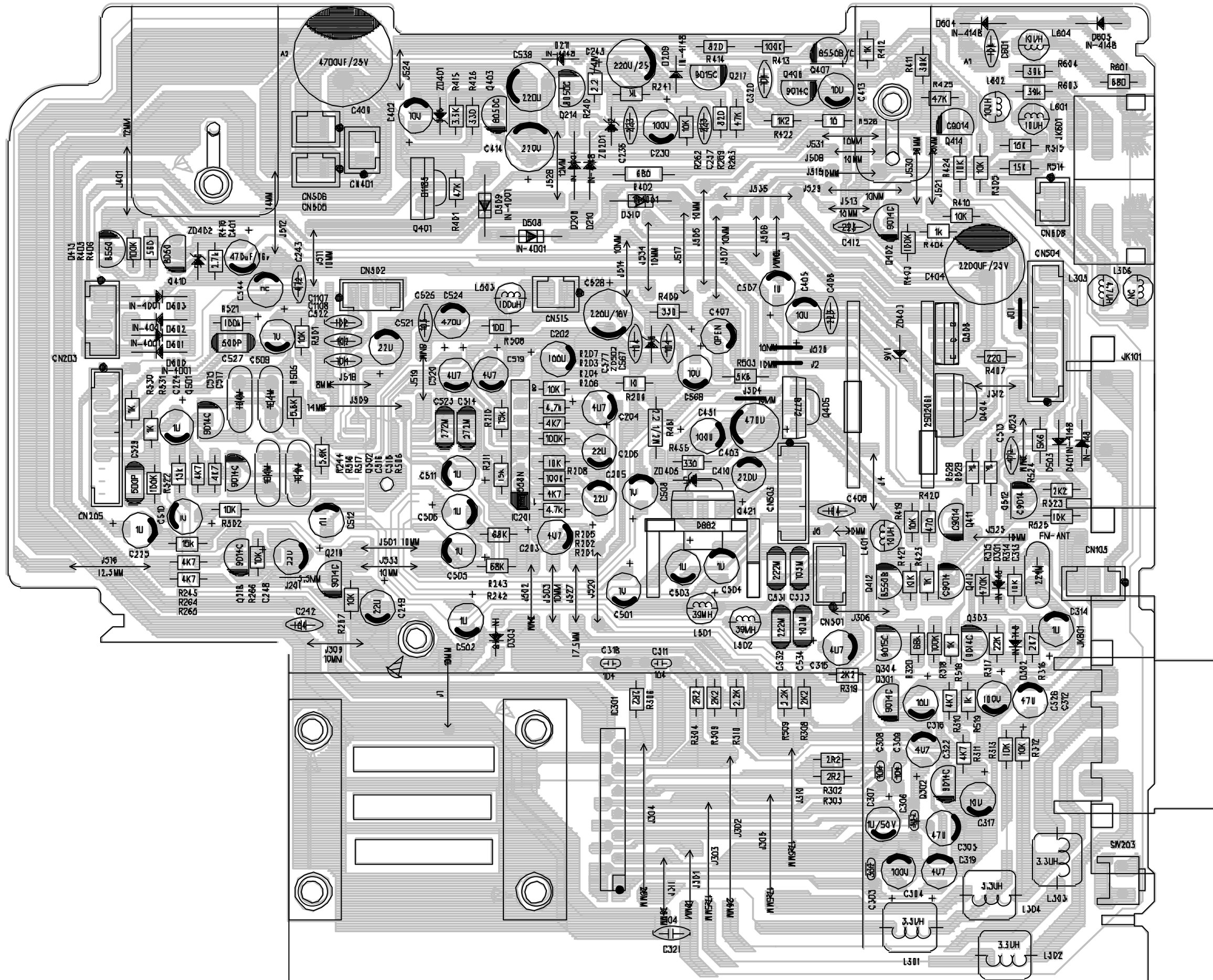

CIRCUIT DIAGRAM - CONTROL BOARD

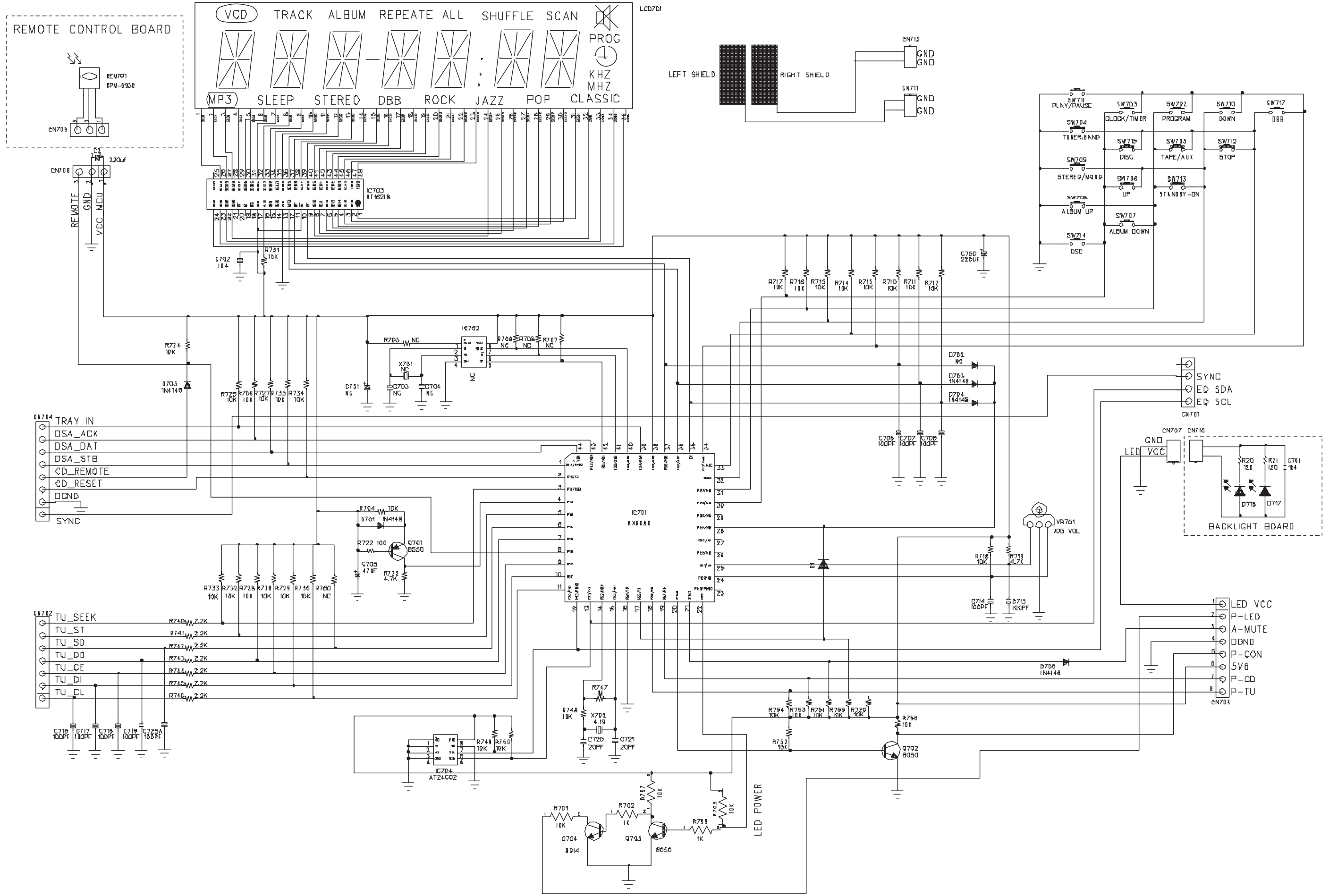

LAYOUT DIAGRAM - CONTROL BOARD

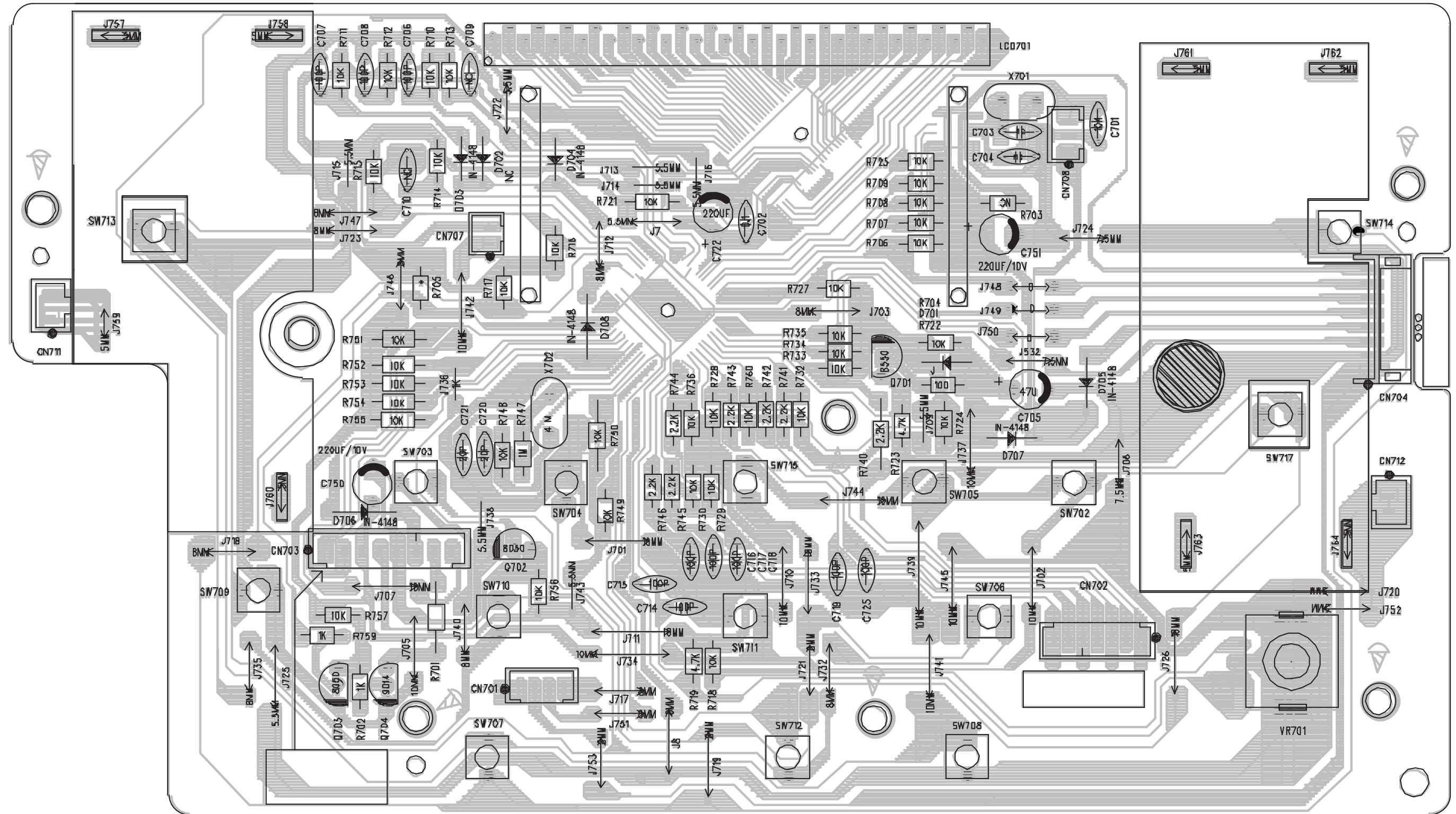

CIRCUIT DIAGRAM - CASSETTE BOARD

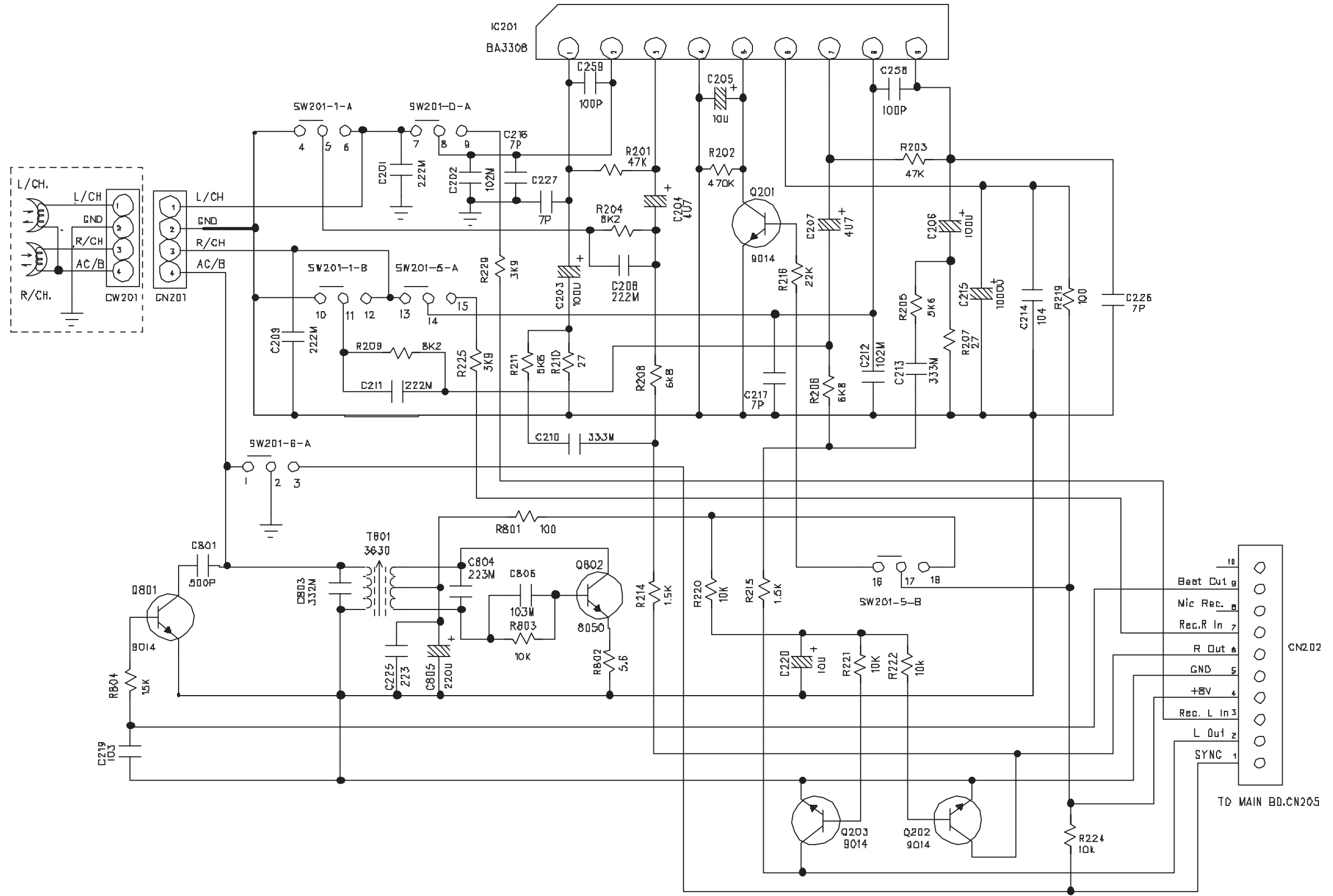

248-STDS13-108
BIAS=80KHz

LAYOUT DIAGRAM - CASSETTE BOARD

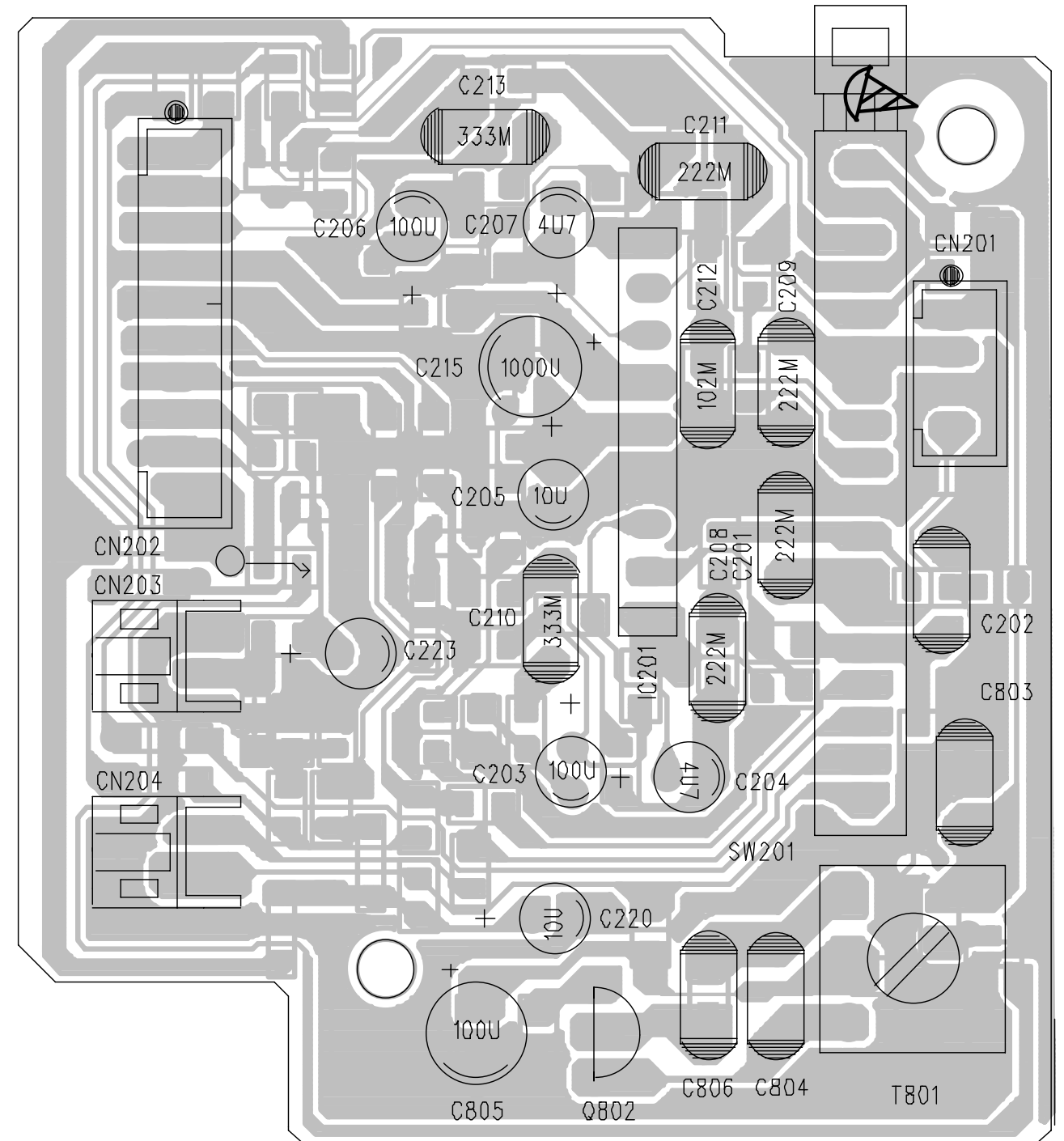
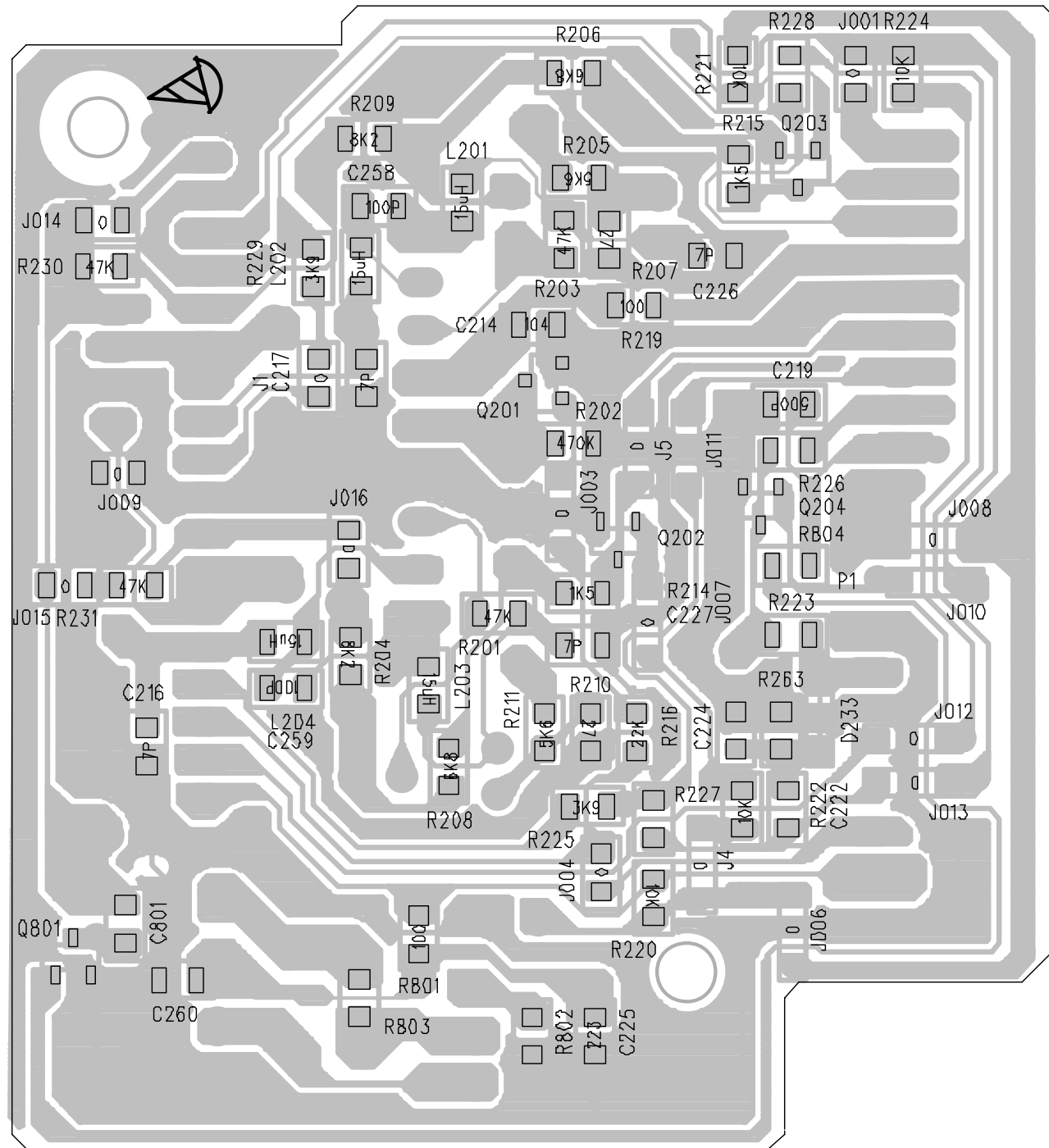

CIRCUIT DIAGRAM - VCD BOARD

VCD board is not repaired, program for reference only.

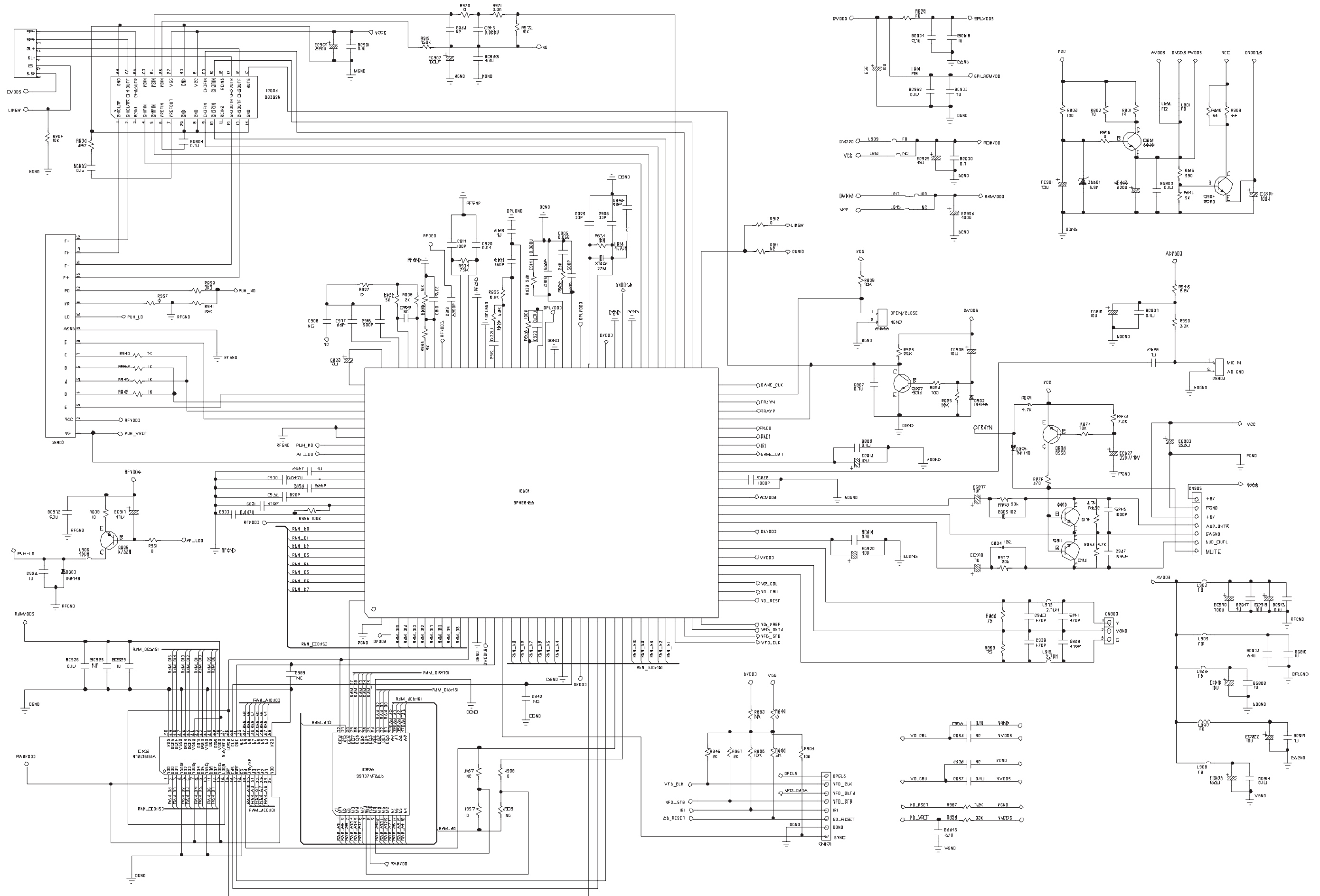

LAYOUT DIAGRAM - VCD BOARD

VCD board is not repaired, program for reference only.

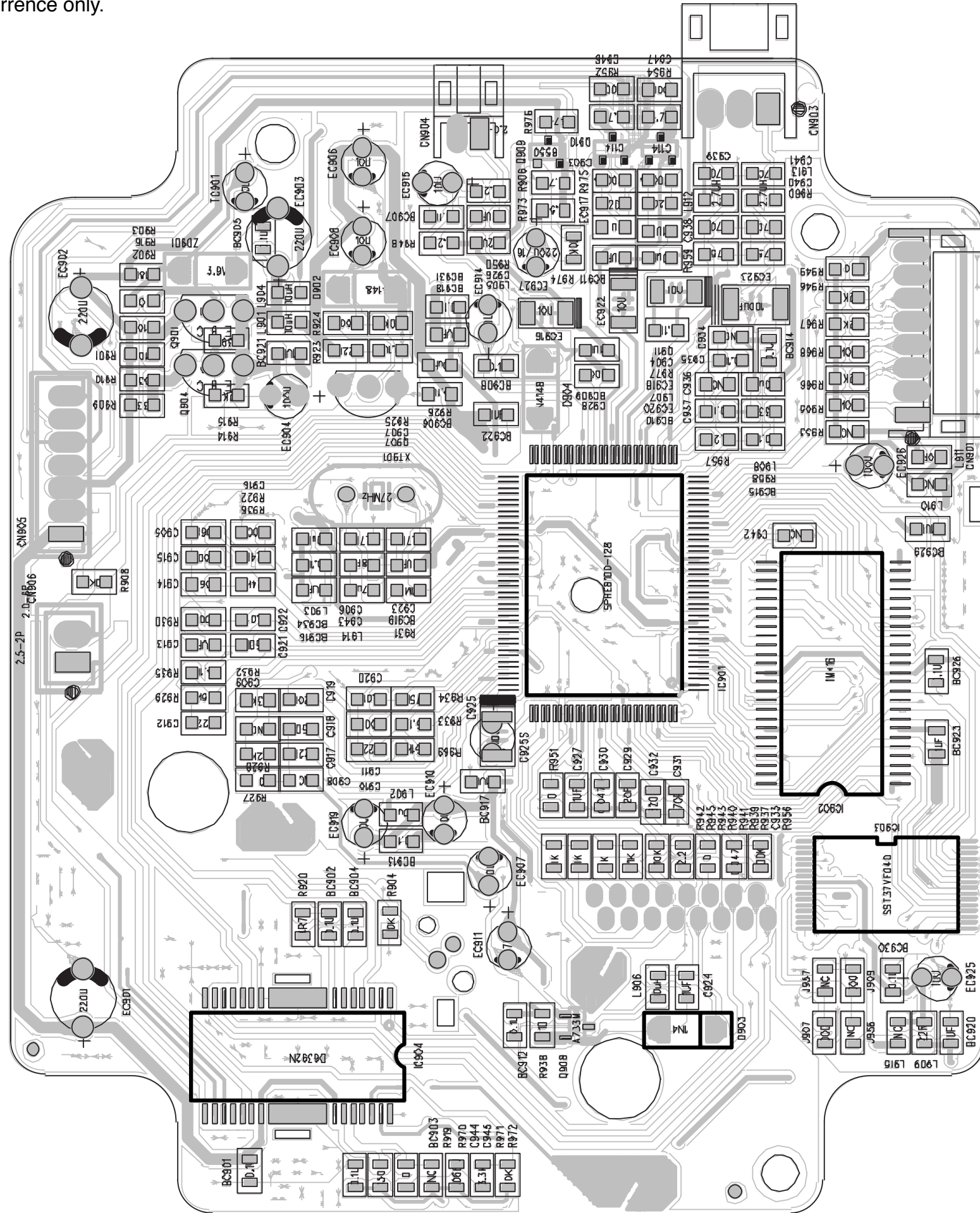

EXPLODED VIEW DIAGRAM

NO	PARTSNAME	MATER	QTY
S23	3 x 25 PB	SCREW	3
S22	3 x 12 PB	SCREW	2
S21	3 x 8 PB	SCREW	3
S20	3 x 8 PB	SCREW	1
S19	3 x 8 PB	SCREW	2
S18	3 x 10 PB	SCREW	2
S17	3 x 20 PWB	SCREW	4
S16	3 x 8 PB	SCREW	2
S15	2 x 4 BB	SCREW	1
S14	3 x 6 KB	SCREW	3
S13	3 x 8 PB	SCREW	2
S12	3 x 8 BB	SCREW	4
S11	3 x 8 BB	SCREW	2
S10	2 x 6 PB	SCREW	1
S9	3 x 10 PB	SCREW	2
S8	3 x 8 PB	SCREW	7
S7	3 x 8 PWB	SCREW	1
S6	3 x 8 PB	SCREW	3
S5	2.6 X 8 PWA	SCREW	4
S4	3 x 10 PB	SCREW	4
S3	3 x 8 PB	SCREW	3
S2	3 x 8 PB	SCREW	2
S1	3 X 8 PWB	SCREW	1

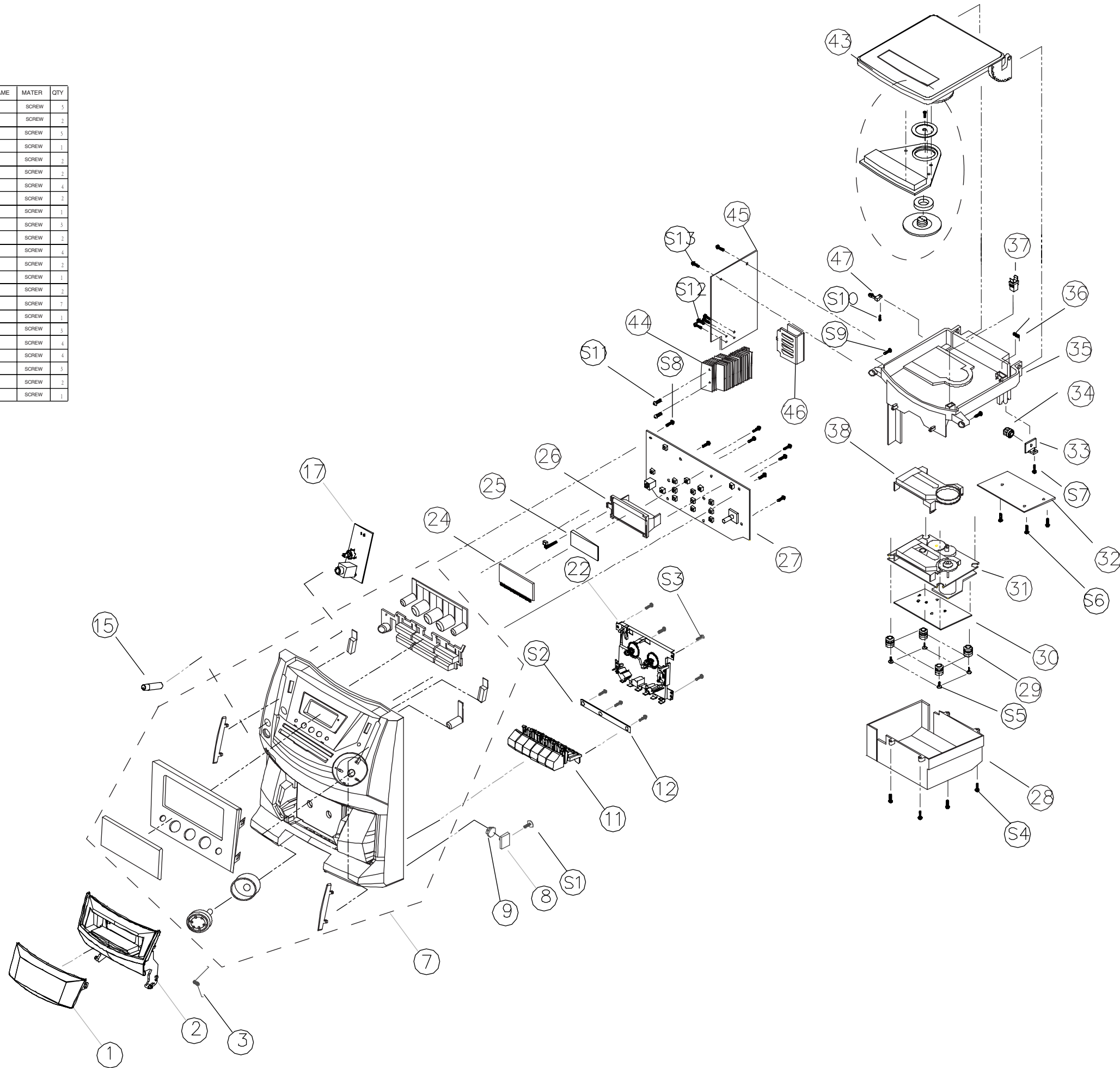

EXPLODED VIEW DIAGRAM

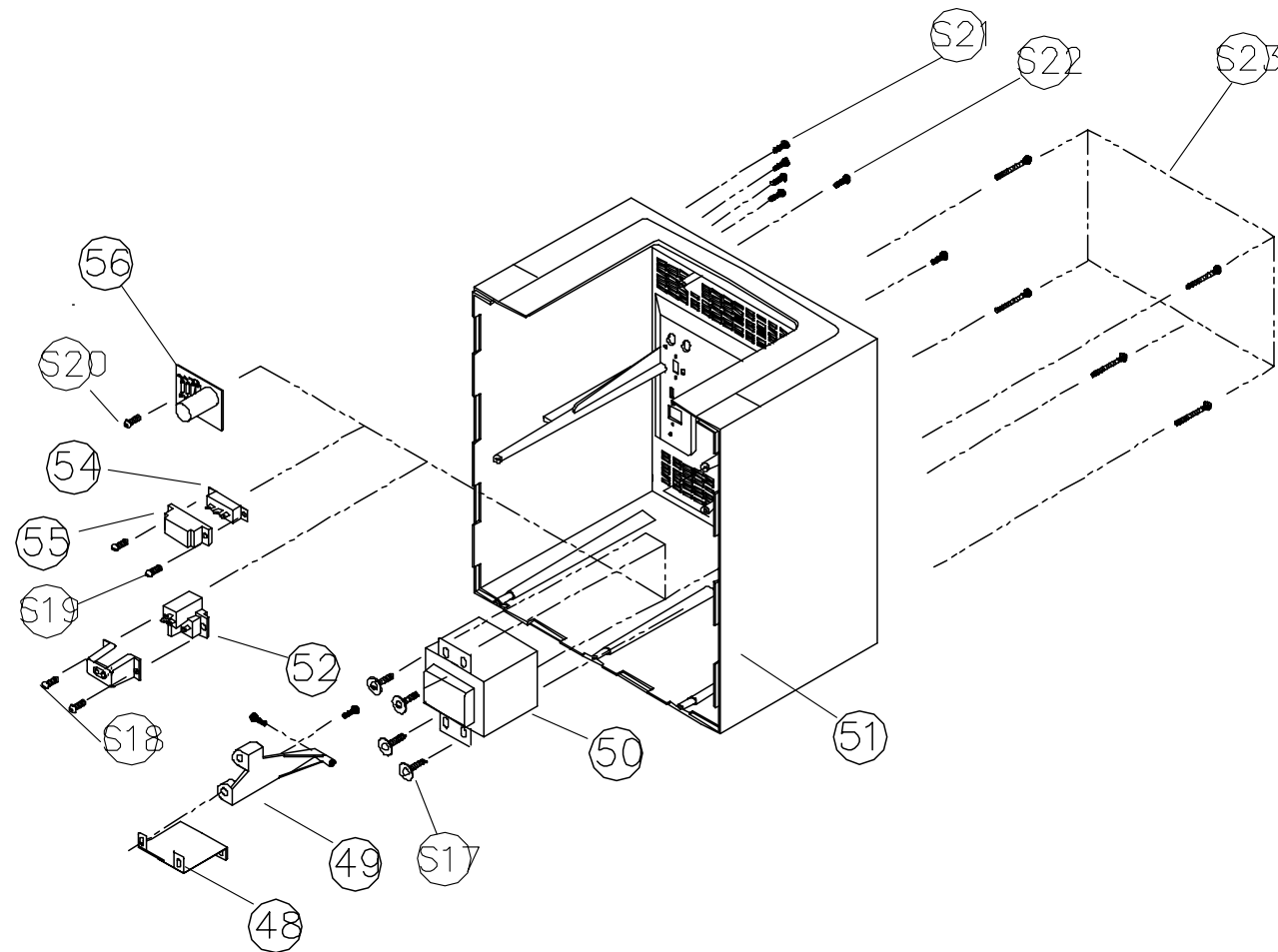

MECHANICAL PARTSLIST

1	994000005057	CASS DOOR LENS
2	994000005058	CASS DOOR
3	994000001743	CASS DOOR SPPING
7	994000005059	FRONT CABINET ASSY
8	994000001761	GEAR HOLER
9	994000001759	GEAR FOR CASS DOOR
15	994000005105	MIC KNOB
22	994000005048	CASS DECK HY-21F-034
25	994000005053	BACK LIGHT BOARD
28	994000005061	CD MECHANISM COVER
29	994000005049	RUBBER SILICON
30	994000005044	FWV135 VCD MPEG
31	994000005045	CD DECK KSM-213CLDM
35	994000005054	CD TRAY
36	994000001742	SPRING FOR CD DOOR
37	994000001744	CD DOOR LOCK
38	994000005062	CD MECHANISM COVER
39	994000005053	CD CHUCK ASSY
43	994000005056	CD DOOR
51	994000005063	BACK CABINET
52	994000002774	AC SOCKET
	994000005047	FM ROD ANTENNA

ACCESSORIES

994000005051	AV CABLE
994000005052	REMOTE CONTROL
994000005046	SPEAKER BOX ASSY
994000001739	AM EXTERNAL ANTENNA

Note: Only these parts mentioned in the list are normal service parts.

ELECTRICAL PARTSLIST - TUNER BOARD

- MISCELLANEOUS -

T101	994000001712	I.F.T 1A612R RED 10mm
L103	994000001713	I.F.T. ANT OA10-871104
T103	994000001714	I.F.T IF 2070 YELLOW
CT101	994000002776	TRIMMER 10 PF RED
CT102	994000002776	TRIMMER 10 PF RED
X101A	994000005019	CRYSTAL 4.5 MHz

- COILS & FILTERS -

CF104	994000005015	CER. FILTER 10.7 MCI-A 2P
CF102	994000005016	CER. FILTER LT10.7MS3 3P
CF103	994000005016	CER. FILTER LT10.7MS3 3P
CF105	994000005017	CERAMIC FILTER FM450AL
CF101	994000005018	BAND PASS FILTER GFMB3

- DIODES -

VD101	994000001709	DIODE VCD/SVC201
VD102	994000001709	DIODE VCD/SVC201
VD103	994000001711	DIODE VCD/SVC348
ZD101	994000005021	ZENER 5.6V 1/2W +-5%

- IC & TRANSISTORS -

Q108	994000005014	TRANSISTOR 2SC-3330U
IC101	994000001707	I.C. SANYO LA-1823-ESIA
IC102	994000001708	I.C. SANYO LC-72131

Note: Only these parts mentioned in the list are normal service parts.

ELECTRICAL PARTSLIST - AUDIO BAORD

- MISCELLANEOUS -

SW203	994000001717	TACT SWITCH
JK101	994000001719	ANTENNA JACK 75 OHM
JK601	994000005025	RCA JACK AV3-8.4-21
JK801	994000001722	SPEAKER TERMINAL

- IC & TRANSISTORS -

Q421	994000005022	TRANSISTOR KSD882Y
Q506	994000005022	TRANSISTOR KSD882Y
Q404	994000002782	TRANSISTOR 2SD-2061E
Q401	994000005023	TRANSISTOR B1185E/F
Q405	994000002777	TRANSISTOR KSB-772Y
IC301	994000001715	I.C. SANYO LA-4628
IC201	994000005024	I.C.ROHM BA-4558N
IC501	994000005026	IC SC7314

Note: Only these parts mentioned in the list are normal service parts.

ELECTRICAL PARTSLIST - CONTROL BOARD**- MISCELLANEOUS -**

SW702	994000002786	TACT SWITCH
SW703	994000002786	TACT SWITCH
SW704	994000002786	TACT SWITCH
SW705	994000002786	TACT SWITCH
SW706	994000002786	TACT SWITCH
SW707	994000002786	TACT SWITCH
SW708	994000002786	TACT SWITCH
SW709	994000002786	TACT SWITCH
SW710	994000002786	TACT SWITCH
SW711	994000002786	TACT SWITCH
SW712	994000002786	TACT SWITCH
SW713	994000002786	TACT SWITCH
SW714	994000002786	TACT SWITCH
SW715	994000002786	TACT SWITCH
SW717	994000002786	TACT SWITCH
X702	994000005031	CRYSTAL 4 MHz HC-49U
LCD701	994000005029	LCD DISPLAY 35 PIN
VR701	994000001728	POTARY ENCODER

- IC & TRANSISTORS -

Q702	994000005027	TRANSISTOR 8050C/D
Q703	994000005027	TRANSISTOR 8050C/D
Q701	994000005028	TRANSISTOR 8550B/C
IC701	994000005032	IC MX10E8050IUC
IC703	994000005033	IC HT1621B
IC704	994000005034	IC S524A40X21-SCBO

Note: Only these parts mentioned in the list are normal service parts.

ELECTRICAL PARTSLIST - MIC JACK BOARD**- MISCELLANEOUS -**

IC601	994000005035	I.C. ROHM BA-4510F
VR601	994000005036	SHAFT VOLUME
JK602	994000005037	ST. PHONE JACK/CK-6.35-



ELECTRICAL PARTSLIST - RECTIFIER BOARD**- MISCELLANEOUS -**

D1101	994000005038	RECTIFIER IN5401
D1102	994000005038	RECTIFIER IN5401
D1103	994000005038	RECTIFIER IN5401
D1104	994000005038	RECTIFIER IN5401
FS1101	 994000005039	FUSE 6.3A 250V 50T

ELECTRICAL PARTSLIST - RECORDING BOARD**- MISCELLANEOUS -**

Q802	994000005041	TRANSISTOR 8050C/D
T801	994000005042	I.F.T. AC BIAS 3630
IC201	994000005043	I.C. BA-3308 P/R HWCAT
SW201	994000001737	RECORDING SW.

ELECTRICAL PARTSLIST**- MISCELLANEOUS -**

D717	994000001729	LED ROUND 53B3SC08
D718	994000001729	LED ROUND 53B3SC08
	994000005044	FWV135 VCD MPEG BOARD
	994000002792	FFC CABLE 16 PINS
	 994000001746	POWER TF.230V 50Hz
	 994000002773	POWER CORD SET

Note: Only these parts mentioned in the list are normal service parts.